

Fixed Displacement Radial Piston Staffa Motor HMB Series

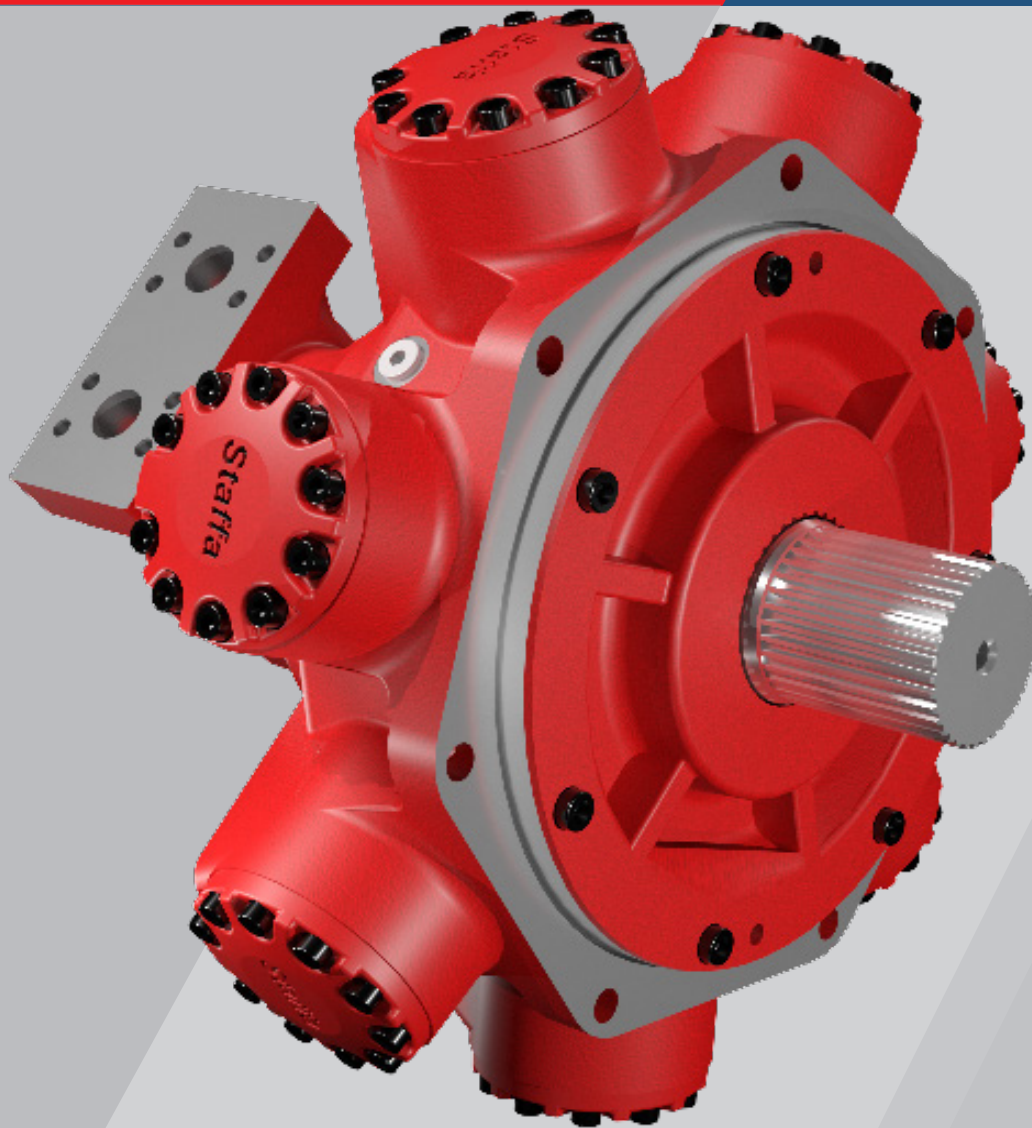

Ordering Code	4
1-1 Model Coding	4
Technical Information	6
2-1 Performance Data	6
2-2 Volumetric Efficiency Data	12
2-3 Shaft Power Calculation	13
2-4 Functional Symbols	14
2-5 Stress Limits	15
2-6 Bearing Life Notes	16
2-7 Circuit and Application Notes	17
2-8 Motor Operation at Low Temperature	20
2-9 Freewheeling Notes	21
2-10 Crankcase Drain Connections	22
2-11 Installation Data	23
2-12 Special Features	24
Dimensions	38
3-1 HMB030	38
3-1 HMB030 (cont)	39
3-1 HMB030 (cont)	40
3-2 HMB045	42
3-2 HMB045 (cont)	44
3-3 HMB060/080	45
3-4 HMB100	48
3-5 HM(HD)B125	51
3-7 HM(HD)B270	61
3-8 HM(HD)B325	66
3-9 HMHDB400	71
3-10 HMB500	73
3-11 Preferred Hydraulic Connections	75

Fixed Displacement Radial Piston Hydraulic Motor

■ General Descriptions

The Kawasaki Staffa range of high torque low speed fixed displacement radial piston hydraulic motors consists of 13 frame sizes ranging from the HMB030 to HMB500. Capacity ranges from 188 to 8,000 cc/rev.

The rugged, well proven design incorporates high efficiency combined with good breakout torque and smooth running capability. Various features and options are available including, on request, mountings to match competitors' interfaces.

The Kawasaki Staffa range also includes dual and triple displacement motors. To obtain details of these product ranges please refer to datasheet M-2002/03.17 and M-2005/12.17



■ Features

- Rugged, reliable, proven design
- Unique hydrostatic balancing provides minimum wear and extended life
- High volumetric and mechanical efficiency
- Capacities range from 188 to 8,000cc/rev
- Large variety of shaft and porting options
- Output torque up to 25,250Nm
- Wide range of mounting interfaces available
- Alternative displacements also available

Date	Revision	Changes
01/01/2019	MYK5849-HMB-data-sheet-A4-REV-21	Original
12/12/2024	M200112.24-HMB	<ul style="list-style-type: none"> • Removal of FM3 FM4 and F3 F4 Valve housing • Replaced with SM and SFM valve housing

1

Ordering Code

1-1 Model Coding

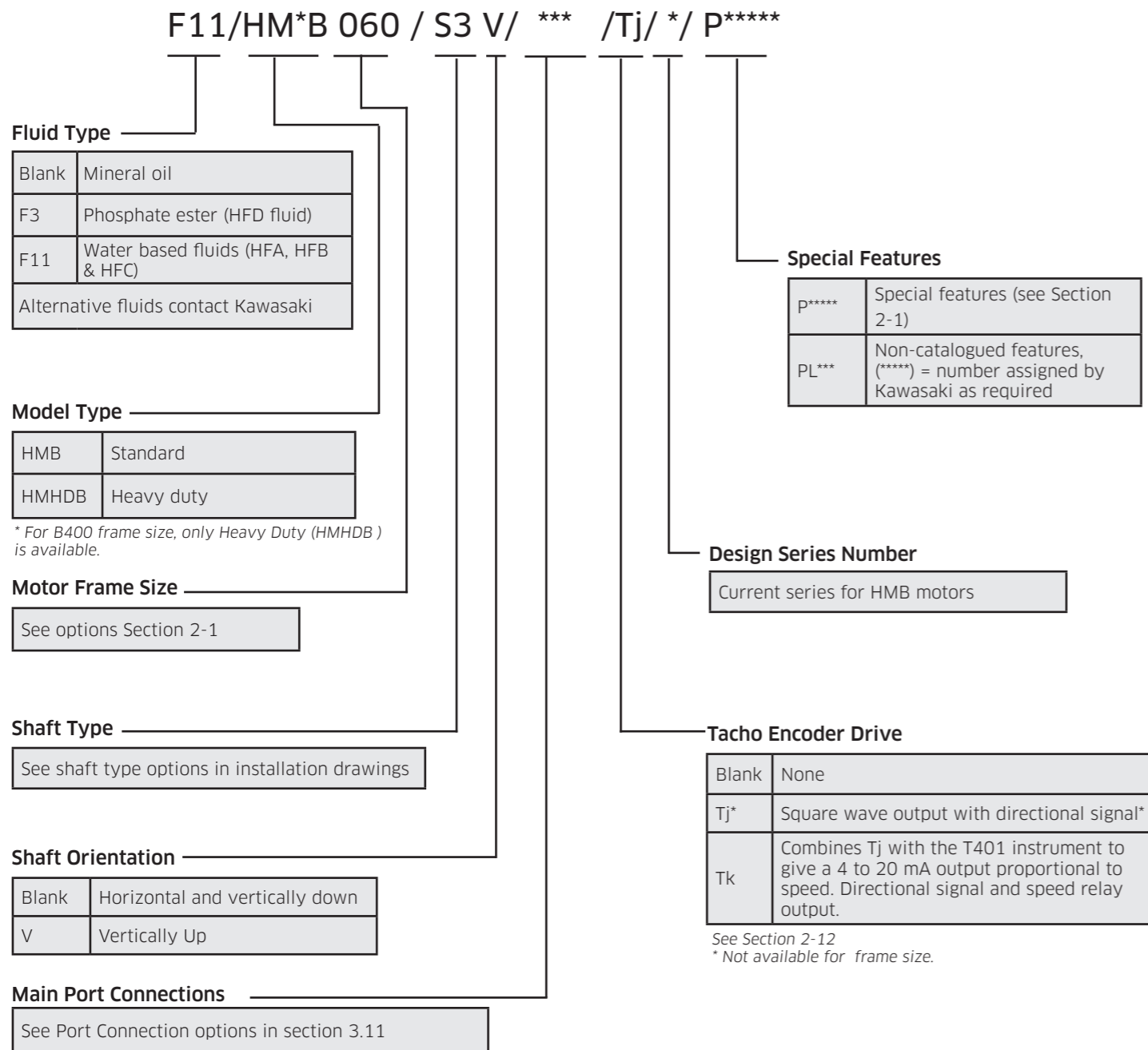

1-1 Model Coding

Special Features Suffix

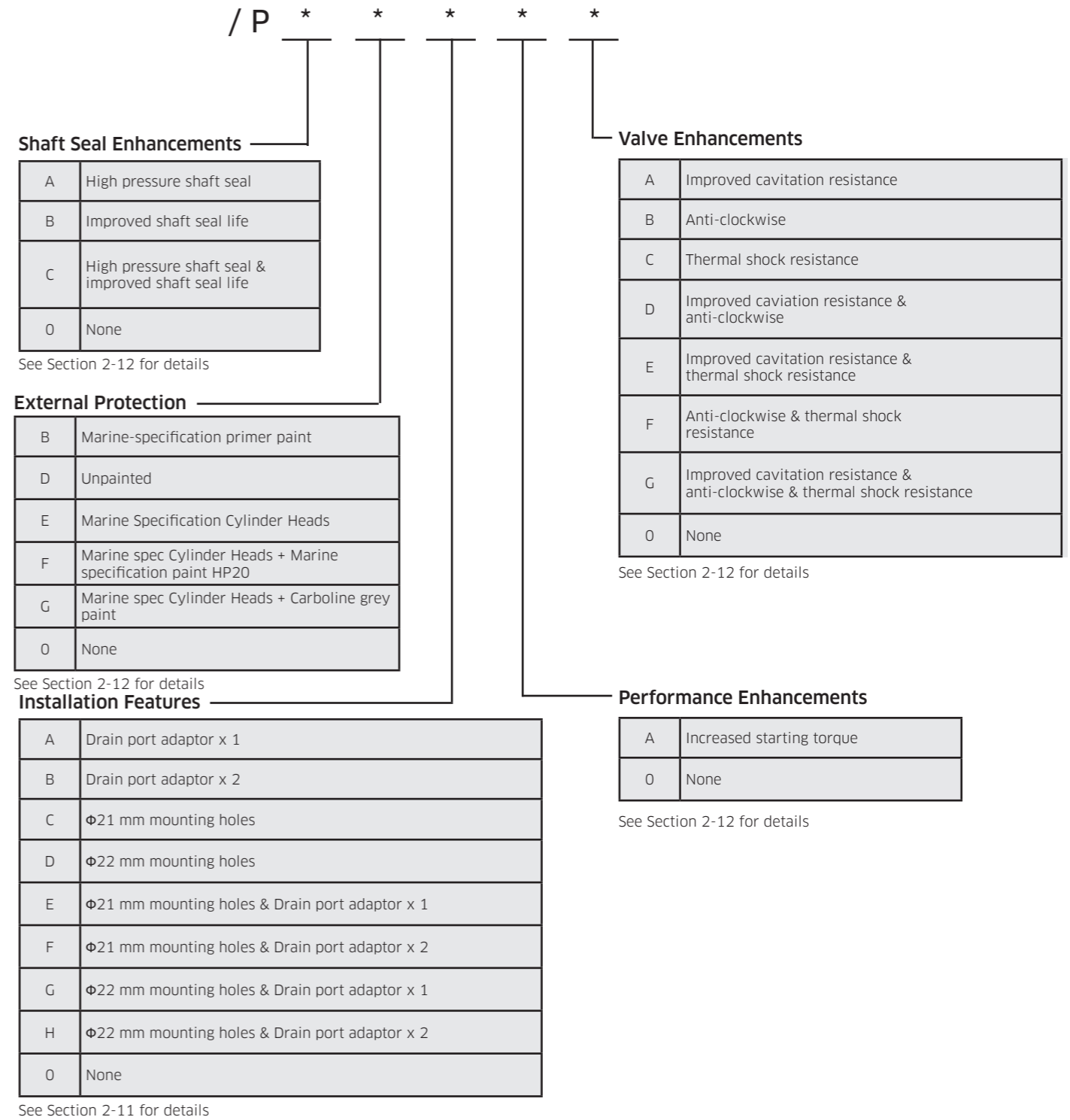

2-1 Performance Data

Rating definitions

Continuous rating

For continuous duty the motor must be operating within each of the maximum values for speed, pressure and power.

Intermittent rating

Operation within the intermittent power rating (up to the maximum continuous speed) is permitted on a 15% duty basis, for periods up to 5 minutes maximum.

Intermittent max pressure

Intermittent max pressure: 300 bar.

This pressure is allowable on the following basis:

- a) Up to 50rpm 15% duty for periods up to 5 minutes maximum.
- b) Over 50rpm 2% duty for periods up to 30 seconds maximum.

Static pressure to DNV rules 405bar (DNV-GL-RU-Ship Part 4) - except HMB030 motors.

Limits for fire resistant fluids

Fluid Type	Continuous Pressure (bar)	Intermittent Pressure (bar)	Max Speed (rpm)	Model Type
HFA 5/95 oil-in-water emulsion	130	138	50% of limits of mineral oil	All models
HFB 60/40 water-in-oil emulsion	138	172	As for mineral oil	All models
HFC water glycol	103	138	50% of limits of mineral oil	All models
HFD Phosphate Ester	207	300	As for mineral oil	HMB030
	250	300	As for mineral oil	HMB045 to HMB400 inc.
	190	227	As for mineral oil	HMB500

2-1 Performance Data

Specifications

Motor Type	Geometric displacement (cc/rev)	Average actual running torque (Nm/bar)	Max. continuous speed (rpm)	Max. continuous output power (kW)	Max. continuous pressure (bar)	Max. intermittent pressure (bar)
HMB030 (HMB010 replacement)	188	2.30	500	18	207	250
HMB030	442	6.56	450	42	207	250
HMB030 (FM3)	492	7.31	450	52	207	250
HMB045	740	10.95	400	60	250	300
HMB060	983	14.5	300	80	250	300
HMB080	1,344	19.9	300	100	250	300
HMB100	1,639	24.3	250	110	250	293
HMB125	2,050	30.66	220	100	250	300
HMHDB125						
HMB150	2,470	36.95	220	115	250	300
HMHDB150						
HMB150 (FM3)	2,470	36.95	168	115	250	300
HMB200	3,087	46.07	175	130	250	300
HMHDB200						
HMB200 (FM3)	3,087	46.07	135	130	250	300
HMB270	4,310	63.79	125	140	250	300
HMHDB270						
HMB325	5,310	79.4	100	140	250	300
HMHDB325						
HMHDB400	6,800	101	120	190	250	300
HMB500	8,000	114	100	170	190	227

Other non standard displacements are possible - check with Kawasaki for details.

2-1 Performance Data (cont)

Output Torque Curves

These torque curves indicate the maximum output torque and power of a fully run-in motor for a range of pressures and speeds when operating with zero outlet pressure on Mineral Oil of 50cSt (232 SUS) viscosity. High return line pressures will reduce torque for a given pressure differential. - x - x - x - Upper limit of continuous rating envelope.

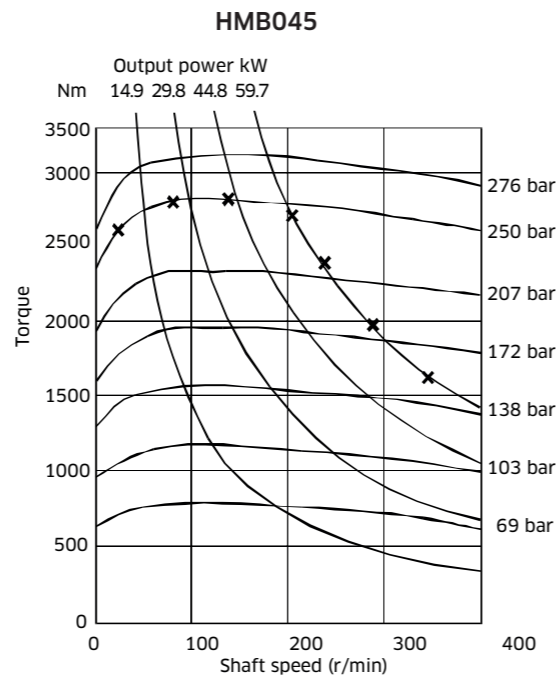
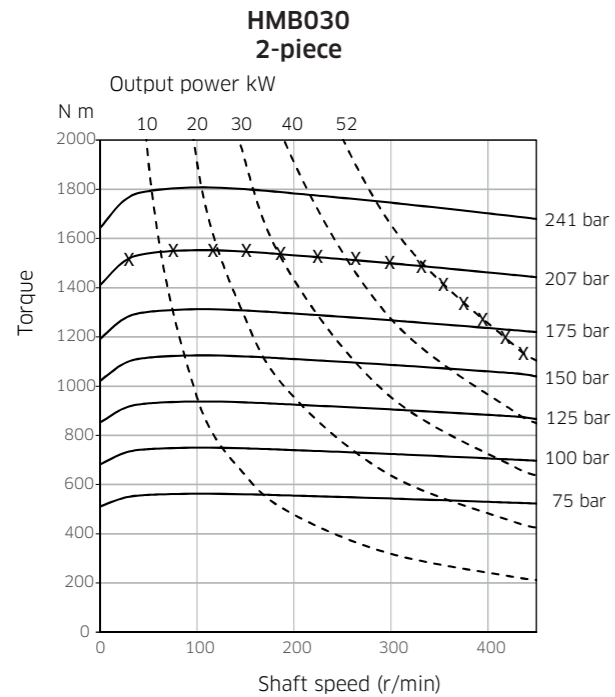
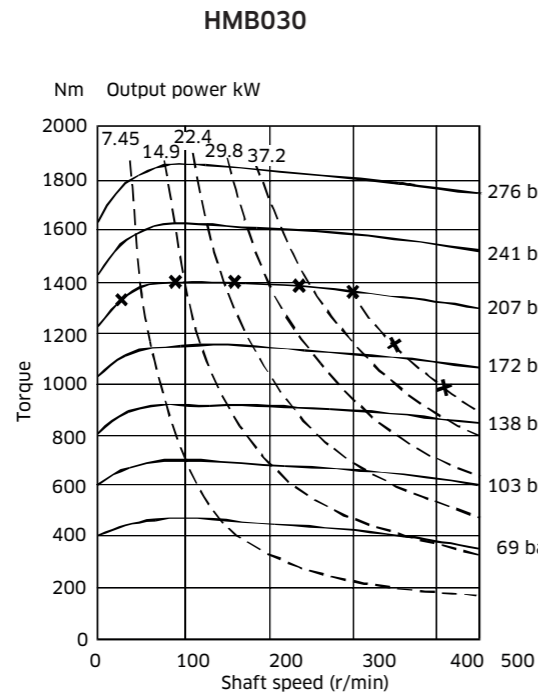

2-1 Performance Data (cont)

Output Torque Curves (cont)

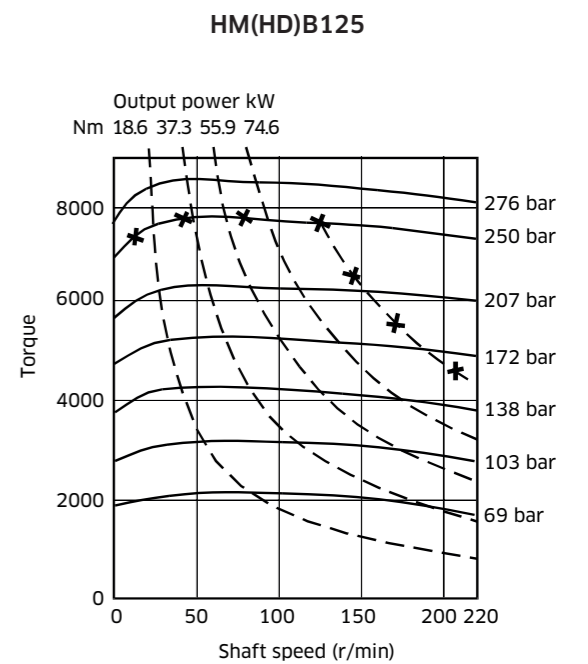
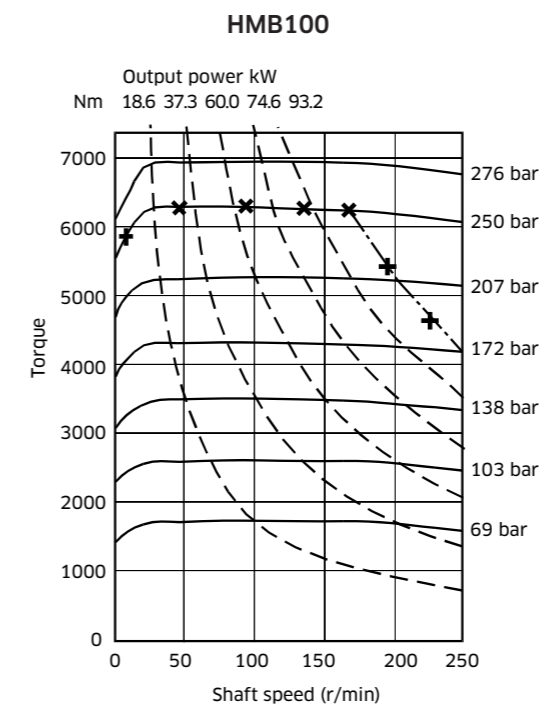
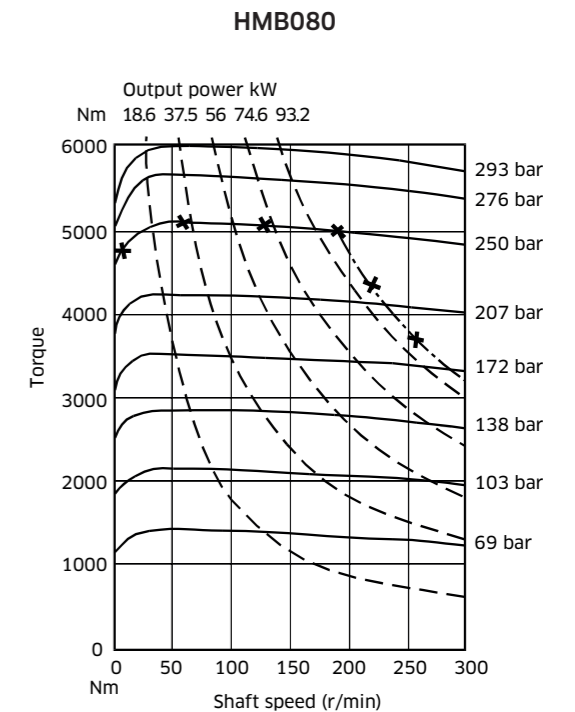
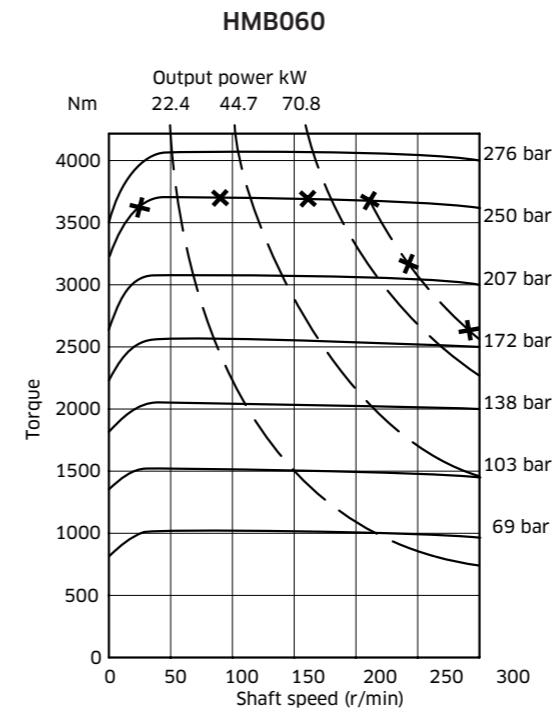

2-1 Performance Data (cont)

Output Torque Curves (cont)

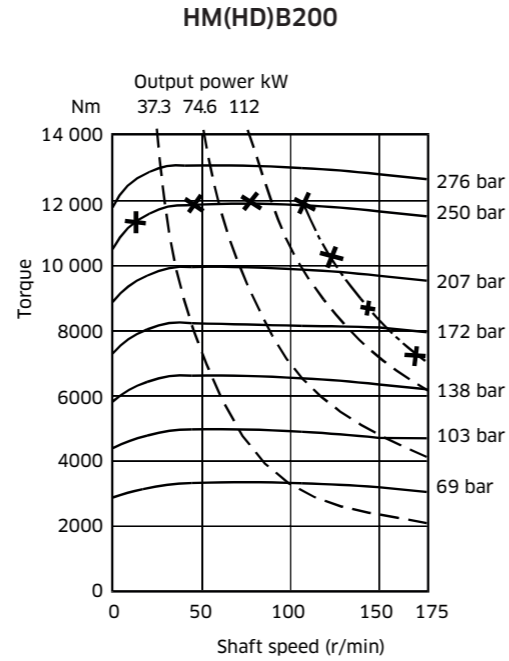
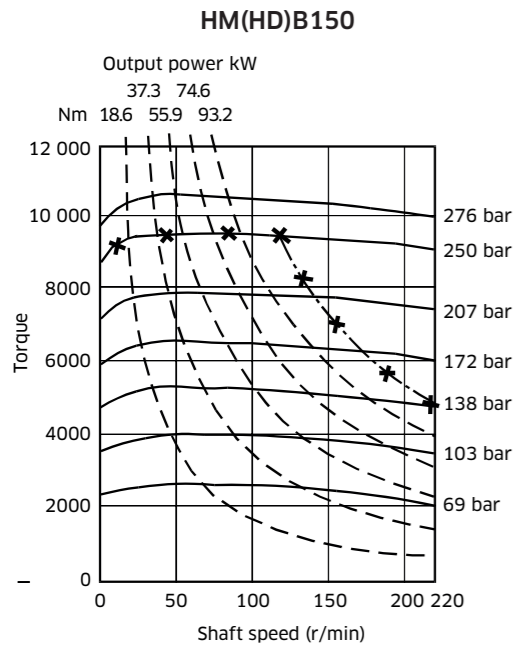

2-1 Performance Data (cont)

Output Torque Curves (cont)

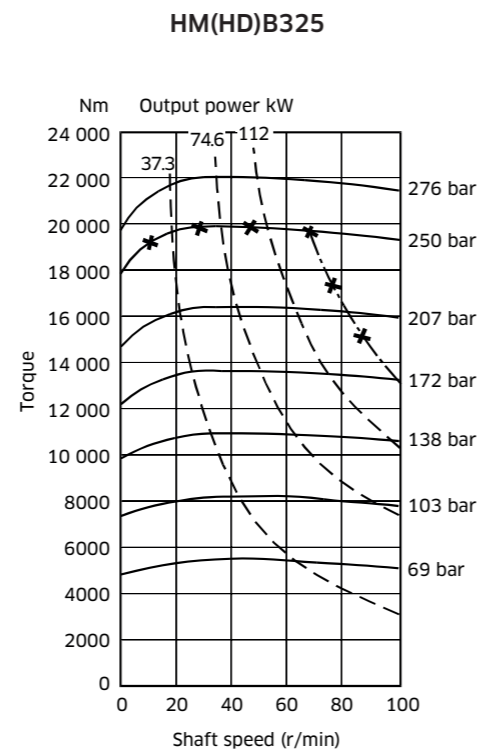
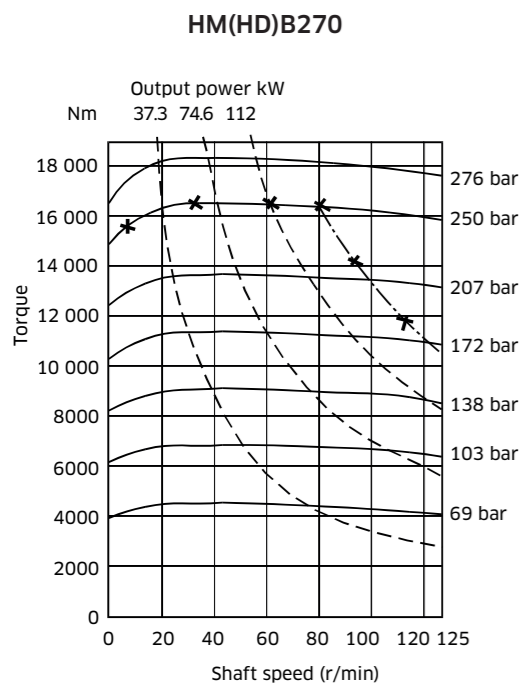
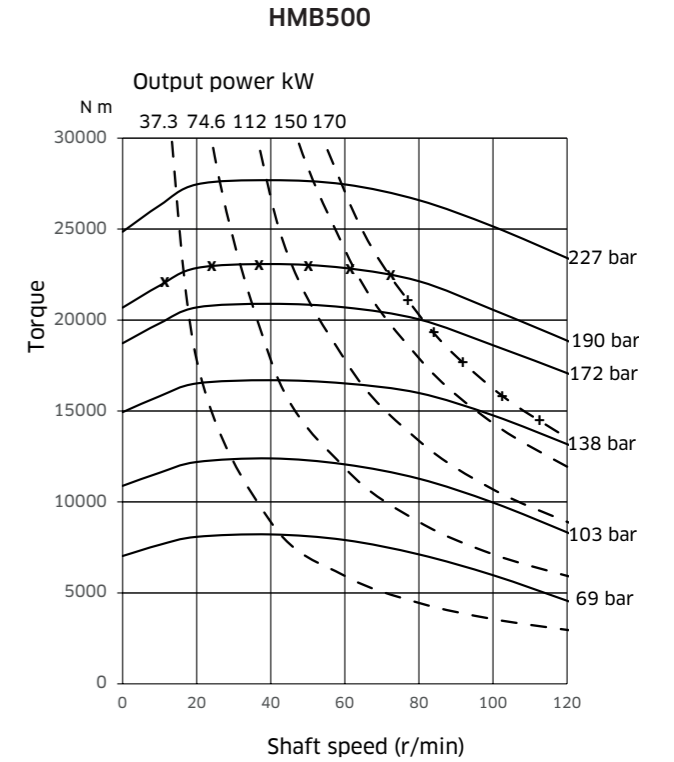
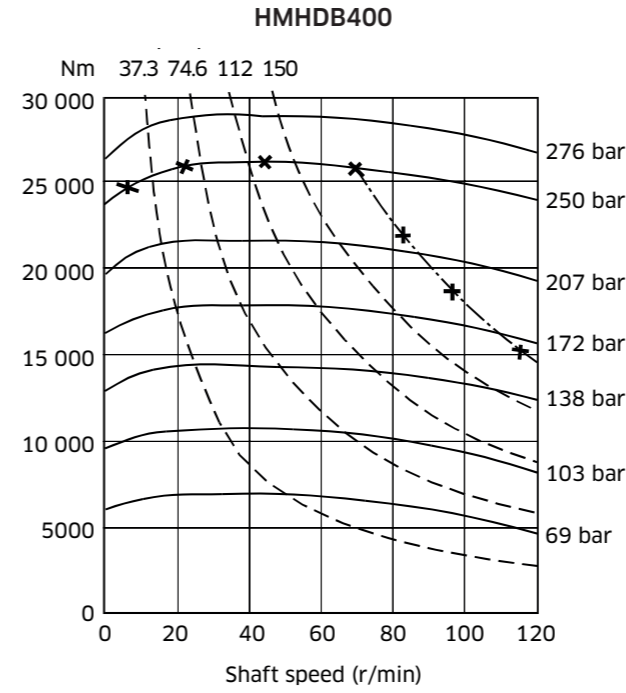

2-2 Volumetric Efficiency Data

Motor Type	Geometric Displacement	Zero Speed Constant	Speed Constant	Creep Speed Constant	Crankcase Leakage Constant
HMB	cc/rev	K ₁	K ₂	K ₃	K ₄
HMB030	442	1.04	57.67	2.47	0.59
2-piece HMB030	492	1.15	51.80	2.35	0.59
HMB045	740	1.92	43.36	2.71	1.76
HMB060	983	1.72	29.91	2.35	1.88
HMB080	1,344	1.71	21.62	1.84	1.84
HMB100	1,639	1.63	19.90	1.41	1.88
HM(HD)B125	2,050	2.06	11.45	1.24	1.35
HM(HD)B150	2,470	1.62	9.98	1.00	1.39
HM(HD)B200	3,087	2.53	14.99	0.78	1.39
HM(HD)B270	4,310	3.17	21.16	0.68	1.80
HM(HD)B325	5,310	3.14	18.21	0.55	1.80
HMHDB400	6,800	4.06	10.18	0.53	2.35
HMB500	8,000	9.247	78.247	1.739	5.797

Fluid Viscosity	Viscosity Factor
cSt	Kv
20	1.58
25	1.44
30	1.30
40	1.10
50	1.00
60	0.88

Qt (total leakage)	= [K ₁ + n/K ₂] x ΔP x Kv x 0.005	L/min
Creep speed	= K ₃ x ΔP x Kv x 0.005	rpm
Crankcase leakage	= K ₄ x ΔP x Kv x 0.005	L/min
ΔP	= differential pressure	bar
n	= speed	rpm

The motor volumetric efficiency can be calculated as follows:

$$\text{Volumetric efficiency (\%)} = \left[\frac{(\text{speed} \times \text{disp.})}{(\text{speed} \times \text{disp.}) + Q_t} \right] \times 100$$

Example:

HMB200 motor with displacement of 3.087 l/rev.

Speed	60rpm
Differential pressure	200bar
Fluid viscosity	50 cSt

Total leakage	= (K ₁ + n/K ₂) x ΔP x Kv x 0.005	L/min
	= (2.53+60/14.99) x 200 x 1 x 0.005	
	= 6.53	L/min

$$\text{Volumetric efficiency} = \left[\frac{(60 \times 3.087)}{(60 \times 3.087) + 6.53} \right] \times 100$$

= 96.6%

2-3 Shaft Power Calculation

Example

Firstly, to find the maximum differential pressure ΔP at rated speed:

Select the rated shaft power (W) for the motor from the performance data table (in Section 2-1). This is presented in kilowatts so must be converted to watts (x1000).

Then also take the actual average running torque in N m/bar (T_o) and the rated shaft speed in rpm (n).

$$W = \frac{T_o \cdot \Delta P \cdot 2\pi \cdot n}{60}$$

Or to find maximum ΔP then use:

$$\Delta P = \frac{60 \cdot W}{2\pi \cdot T_o \cdot n}$$

HMB270 Example:

Rated shaft power, W (W):	140,000
Average actual running torque, T _o (Nm/bar):	63.79
Rated shaft speed, n (rpm):	125

$$\Delta P = \frac{60 \times 140,000}{2\pi \times 63.79 \times 125}$$

ΔP= 167 bar (max.)

Secondly, to find the maximum speed at rated pressure (using the same information as before):

$$n = \frac{60 \cdot W}{2\pi \cdot T_o \cdot \Delta P}$$

Rated pressure (bar): 250

$$n = \frac{60 \times 140,000}{2\pi \times 63.79 \times 250}$$

n = 83rpm (max.)

In summary, operating the motor within its shaft power limit, at rated speed, would give a maximum pressure of 167 bar, and operating the motor at rated pressure, would give a maximum speed of 83rpm.

Notes

- 1) The maximum calculated speed is based on a rated inlet pressure of 250bar.
- 2) The maximum shaft power is only allowable if the motor drain temperature remains below 80°C.
- 3) The maximum calculated differential pressure assumes that the low pressure motor port is less than 30bar.

2-4 Functional Symbols

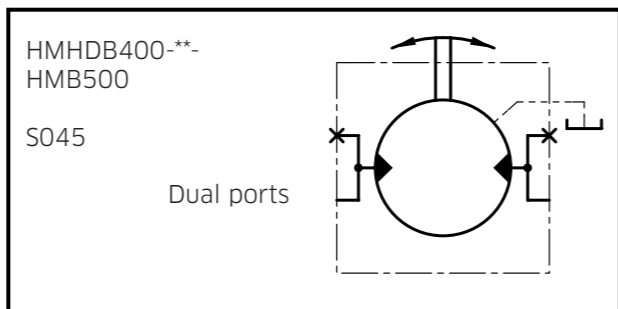
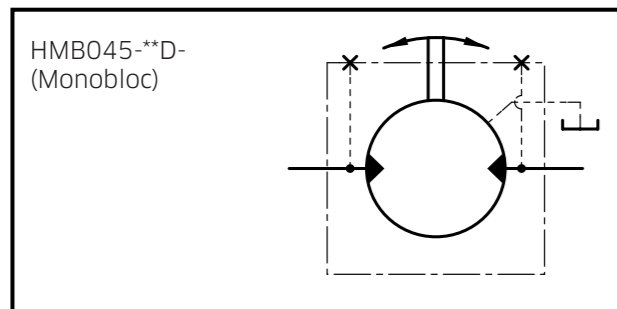
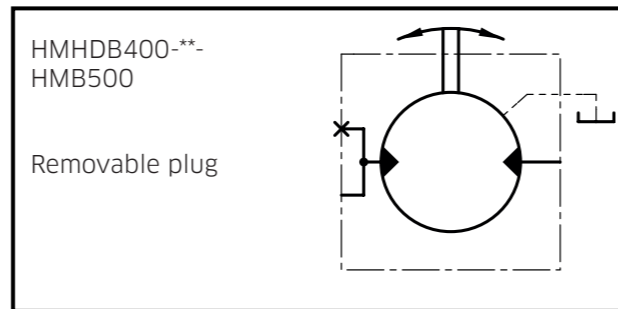
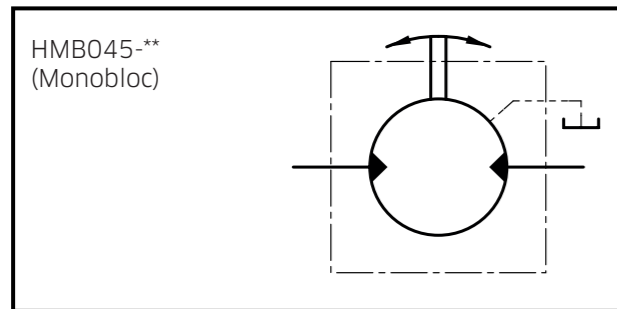
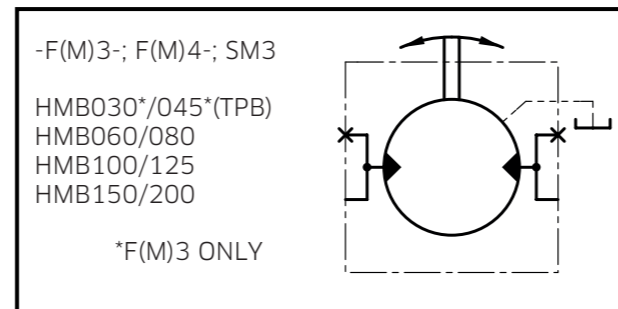
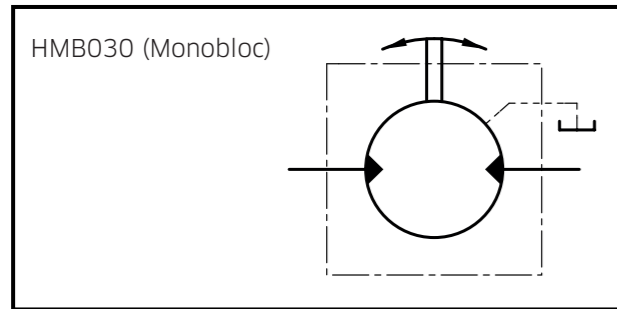

2-5 Stress Limits

When applying large external radial loads, consideration should also be given to motor bearing lives (see Section 2-6).

Motor Frame Size	Shaft Types	Maximum External Radial Bending Moment [Nm]
HMB030	P, S & Z	2,400
HMB045	P, S & Z	3,240
HM060, 080 & 100	P, S, Z & T	5,500
HMB125, 150 & 200	P1, S3, S4, Z3, & T	6,600
HMHDB125, 150, 200	S5, Z5 & P2	12,750
HMB270 & 325	P1, S3, Z3 & T	7,500
HMHDB270 & 325	P2, S5 & Z5	15,900
HMHDB400	P, S & Z	16,200
HMB500	P, S & Z	16,200

Example:

Determine the maximum radial shaft load of a HMB080 motor:

Radial load offset, A = 100mm
 Maximum radial load, W = 5,500 (see table)/100
 = **55kN (5,607 kg)**

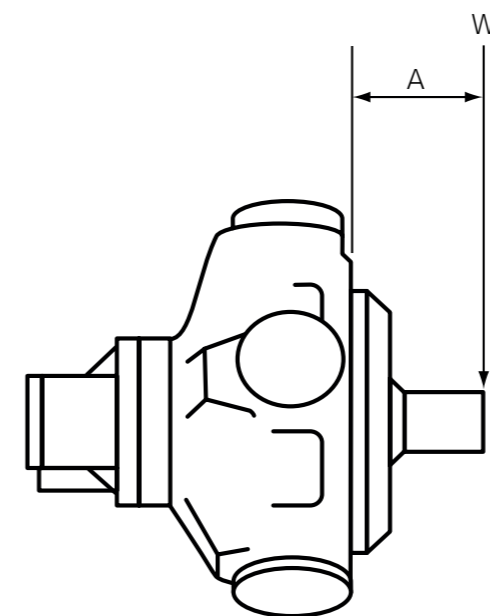

A = Distance from mounting face to load centre (mm)

W = Side load (N)

NOTE:

The offset distance A is assumed to be greater than 50mm. Contact Kawasaki if this is not the case.

2-6 Bearing Life Notes

Consideration should be given to the required motor bearing life in terms of bearing service life. The factors that will determine bearing life include:

- 1) Duty cycle - time spent on and off load
- 2) Speed
- 3) Differential pressure
- 4) Fluid viscosity
- 5) External radial shaft load
- 6) External axial shaft load

NOTE:

A heavy duty HM(HD)B motor can be ordered to further improve bearing life. Consult Kawasaki for a detailed bearing life calculation.

2-7 Circuit and Application Notes

Starting torque

The starting torques shown on the graphs in Section 2-1 are average and will vary with system parameters.

Low Speed Operations

Minimum operating speeds are determined by the hydraulic system and load conditions (load inertia, drive elasticity, etc.) Recommended minimum speeds are shown below:

Model Type	rpm
HMB030	5
HMB045	6
HMB060/080/100	3
HM(HD)B/125/150/200	3
HM(HD)B270/325	2
HMHDB400/HMB500	2

High Back Pressure

When both inlet and outlet ports are pressurised continuously, the lower port pressure must not exceed 70 bar at any time.

NOTE: High back pressure reduces the effective torque output of the motor.

Boost Pressure

When operating as a motor the outlet pressure should equal or exceed the crankcase pressure. If pumping occurs (i.e. overrunning loads) then a positive pressure, "P", is required at the motor ports. Calculate "P" (bar) from the operating formula Boost Formula $P = \frac{1 + N^2 \times V^2}{K} + C$

$$P = \frac{1 + N^2 \times V^2}{K} + C$$

Where P is in bar, N = motor speed (rpm), V = motor displacement (cc/rev), C = crankcase pressure (bar) and K=a constant from the table below:

Motor	Porting	Constant (K)
HMB030	Standard - Monobloc	3.7×10^9
	F(M)3 SM3	7.5×10^9
HMB045	Standard - Monobloc	1.3×10^{10}
	F(M)3 SM3	1.6×10^{10}
HMB060, HMB080 & HMB100	F(M)3 SM3	1.8×10^{10}
HM(HD)B125, HM(HD)B150 & HM(HD)B200	FM(3) SM3	4.0×10^{10}
	FM(4)	8.0×10^{10}
HM(HD)B270 & HM(HD)B325	FM(4)	7.2×10^{10}
HMHDB400 & HMB500	SO4 SO45	7.2×10^{10}

2-7 Circuit and Application Notes (cont)

The flow rate of oil needed for the make-up system can be estimated from the crankcase leakage data (see Section 2-1 for calculation method). Allowances should be made for other system losses and also for “fair wear and tear” during the life of the motor, pump and system components.

Cooling Flow

Operating within the continuous rating does not require any additional cooling.

For operating conditions above “continuous”, up to the “intermittent” rating, additional cooling oil may be required. This can be introduced through the spare crankcase drain ports.

Consult Kawasaki about such applications.

Motorcase pressure

With the standard shaft seal fitted, the motor casing pressure should not exceed 3.5 bar.

NOTES

- 1) The casing pressure at all times must not exceed either the motor inlet or outlet pressure.
- 2) High pressure shaft seals are available for casing pressures of:
10bar for all remaining frame sizes.
- 3) Check installation dimensions for maximum crankcase drain fitting depth.

 **CAUTION**

For trouble free operation the motor's crankcase pressure must always be lower than both of the motor port pressures:

$$P_{case} < P_{in} \quad \text{and} \quad P_{case} < P_{out}$$

Hydraulic Fluids

Dependent on motor (see model code fluid type - Section 1-1) suitable fluids include:

- a) Antiwear hydraulic oils
- b) Phosphate ester (HFD fluids)
- c) Water glycols (HFC fluids)
- d) 60/40% water-in-oil emulsions (HFB fluids)
- e) 5/95% oil-in-water emulsions (HFA fluids)
- f) Antiwear environmentally acceptable lubricants (EALs)

Some fluids require a reduction in pressure and speed limits. Please see table in Section 1-1.

Viscosity limits when using any fluid except oil-in-water (5/95) emulsions are:

- Max. off load:** 2,000cSt (9270 SUS)
- Max. on load:** 150cSt (695 SUS)
- Optimum:** 50cSt (232 SUS)
- Minimum:** 25cSt (119 SUS)

Temperature limits

- Ambient min.** -30°C (-22°F)
- Ambient max.** +70°C (158°F)
- Max. operating temperature range.
- Mineral oil** **Water containing**
- Min** -20°C (-4°F) +10°C (50°F)
- Max.** +80°C (175°F) +54°C (130°F)

NOTE: To obtain optimum services life from both fluid and hydraulic systems components, a fluid operating temperature of 40°C is recommended.

2-7 Circuit and Application Notes (cont)

Mineral oil recommendations

The fluid should be a good hydraulic grade, non-detergent mineral oil. It should contain anti-oxidant, antifoam and demulsifying additives. It must contain antiwear or extreme pressure (EP) additives. Automatic transmission fluids and motor oils are not recommended.

Biodegradable Fluid Recommendations

Well-designed environmentally acceptable lubricants (EALs) may be used with Staffa motors. The EAL must be designed for use in hydraulic systems and have a synthetic ester base. Additives should be as listed for mineral oils, above. The performance of EALs with hydraulic systems vary widely and so checks for seal compatibility, copper alloy compatibility, oxidation resistance and lubrication properties should be carried out before selecting an EAL. For help with EALs please contact Kawasaki.

Polar moment of inertia and mass table

Motor Frame Size	Polar Moment of Inertia (kg m ²) (Typical data)	Mass (kg) (Approx. all models)
HMB030	0.0150	73
HMB045	0.0470	120
HMB060	0.0500	144
HMB080	0.0600	144
HMB100	0.0760	144
HMB125	0.2200	217
HMB150	0.2500	265
HMB200	0.2700	265
HMB270	0.4900	420
HMB325	0.5000	429
HMHDB400 - S04	0.5400	481
HMHDB400 - S045	0.5400	510
HMB500	0.5400	510

Filtration

Full flow filtration (open circuit), or full boost flow filtration (closed circuit) to ensure system cleanliness to ISO4406 code 22/18/13 or cleaner.

Noise levels

The airborne noise level is less than 66.7dB(A) DIN & dB(A) NFPA through the continuous operating envelope. Where noise is a critical factor, installation resonances can be reduced by isolating the motor by elastomeric means from the structure and the return line installation. Potential return line resonances originating from liquid borne noise can be further attenuated by providing a return line back pressure of 2 to 5bar.

2-8 Motor Operation at Low Temperature

When operating the motor at low temperature consideration should be given to the fluid viscosity. The maximum fluid viscosity before the shaft should be turned is 2,000cSt. The maximum fluid viscosity before load is applied to the motor shaft is 150cSt.

If low ambient temperature conditions exist, then a crankcase flushing flow of at least 5 l/min should be applied to the motor during periods when the motor is not in use.

The shaft seal temperature limits for both medium and high pressure applications are shown in the table below.

	Non-operating temperature limits	Minimum operating temperature
Standard pressure shaft seal	below minus 40°C and above 100°C	minus 30°C
High pressure shaft seal	below minus 30°C and above 120°C	minus 15°C

All seals are very brittle below minus 40°C and are likely to break very easily and due to their sluggish response may not provide a 100% leak free condition.

It should be noted that the maximum continuous operating temperature within the motor crankcase is plus 80°C.

2-9 Freewheeling Notes

All Staffa motors can be used in freewheeling applications.

In all circumstances it is essential that the motor is unloaded (A and B ports connected together) and that the circuit is boosted.

The required boost pressure is dependent on both the speed and displacement conditions.

It should be noted that for HMB series motors, to achieve freewheel, large flows will have to re-circulate around the motor.

This will require a large recirculating valve and consideration of circuit cooling as the motor will be generating a braking torque.

It is for these reasons that HMC, HPC or HMF series motors are the preferred option for freewheeling applications.

See catalogues M-2002/03.17, M-2003/03.17 and M-2005/12.17 for details.

2-10 Crankcase Drain Connections

Motor axis - horizontal

The recommended minimum pipe size for drain line lengths up to approx. 5m is 12.0mm (½") bore. Longer drain lines should have their bore size increased to keep the crankcase pressure within limits.

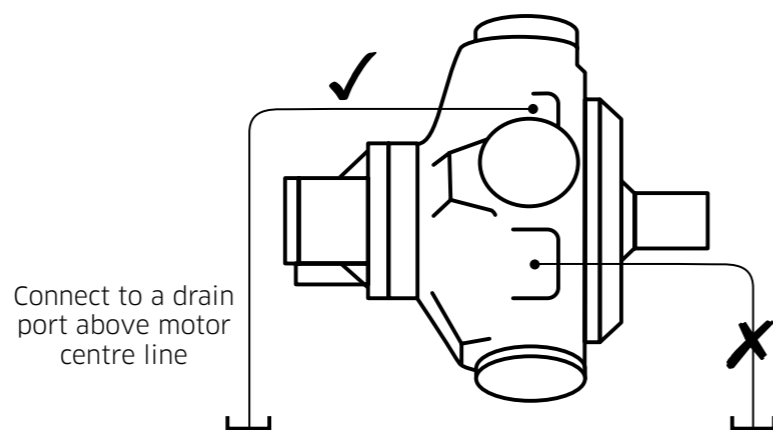

Motor axis - vertical shaft up

Specify "V" within the model code for extra drain port, G¼" (BSPF). Connect this port into the main drain line downstream of a 0.35bar check valve to ensure good bearing lubrication. The piping arrangement must not allow syphoning from the motorcase. (refer to installation drawing for details).

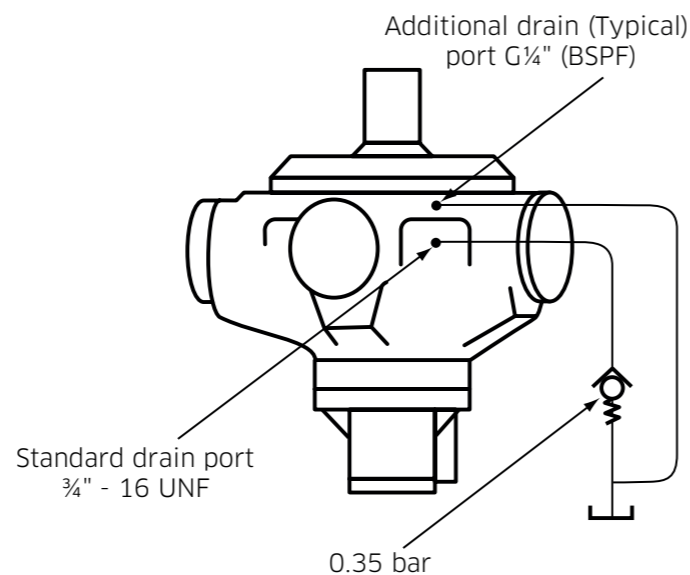

Motor axis - vertical shaft down

The piping, from any drain port, must be taken above the level of the motorcase to ensure good bearing lubrication. The arrangement must not allow syphoning from the motorcase.

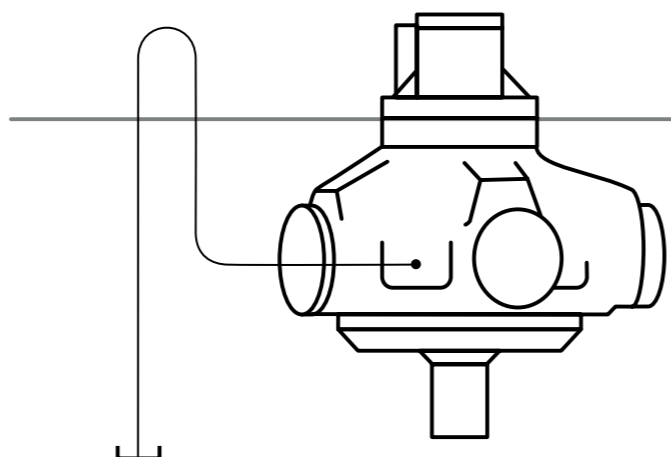

2-11 Installation Data

Spigot

The motor should be located by the mounting spigot on a flat, robust surface using correctly sized bolts.

The diametrical clearance between the motor spigot and the mounting must not exceed 0.15mm. If the application incurs shock loading, frequent reversing or high speed running, then high tensile bolts should be used, including one fitted bolt.

Bolt Torque

The recommended torque wrench setting for bolts is as follows:

M12	97 +/- 7Nm
M14	160 +/- 21Nm
M18	312 +/- 14 Nm
M20	407 +/- 14 Nm
M24	690 +/- 27 Nm
½" UNF	97 +/- 7 Nm
¾" UNF	265 +/- 14 Nm
1" UNF	393 +/- 14 Nm
1"	810 +/- 27 Nm

Shaft Coupling

Where the motor is solidly coupled to a shaft having independent bearings the shaft must be aligned to within 0.13mm TIR.

End of Motor Life

The motor unit must be completely empty upon disposal. It must be disposed of according to national regulations and safety information for the disposal of hydraulic fluids

All individual parts of the motor unit must be recycled. Separate the motor unit parts according to: cast iron, steel, aluminium, non-ferrous metal, electronic waste, plastic, and seals.

2-12 Special Features

Feature	Section	HMB 030	HMB 030 -F(M)3 HMB 030 -SM3	HMB 045	HMB 045 -F(M)3 HMB 045 -SM3	HMB 060/080	HMB 100	HM(HD)B 125	HM(HD)B 150/200	HM(HD)B 270	HM(HD)B 325	HMHDB 400	HMB 500
High Pressure Shaft Seal	2-12	●	●	●	●	●	●	●	●	●	●	●	●
Improved Shaft Seal Life	2-12	●	●	●	●	●	●	●	●	●	●	●	●
Improved Cavitation Resistance	2-12	○	●	○	●	●	●	●	●	●	●	●	●
Increased Starting Torque	2-12	●	●	●	●	●	●	●	●	●	●	●	○
Anti-clockwise Rotation	2-12	●	●	●	●	●	●	●	●	●	●	●	●
Thermal Shock Resistance	2-12	○	●	○	●	●	●	●	●	●	●	●	○
Drain Port Adaptor - 1/2" BSPP	2-12	●	●	●	●	●	●	●	●	●	●	●	●
Φ21mm Mounting Holes	2-12	○	○	○	○	●	●	●	●	●	●	●	●
Φ22mm Mounting Holes	2-12	○	○	○	○	●	●	●	●	●	●	●	●
Marine-specification Primer Paint	2-12	●	●	●	●	●	●	●	●	●	●	●	●

- Available
- Not available

If a motor is to be ordered with any special features listed, please contact Kawasaki.

2-12 Special Features (cont)

◆ High Pressure Shaft Seal

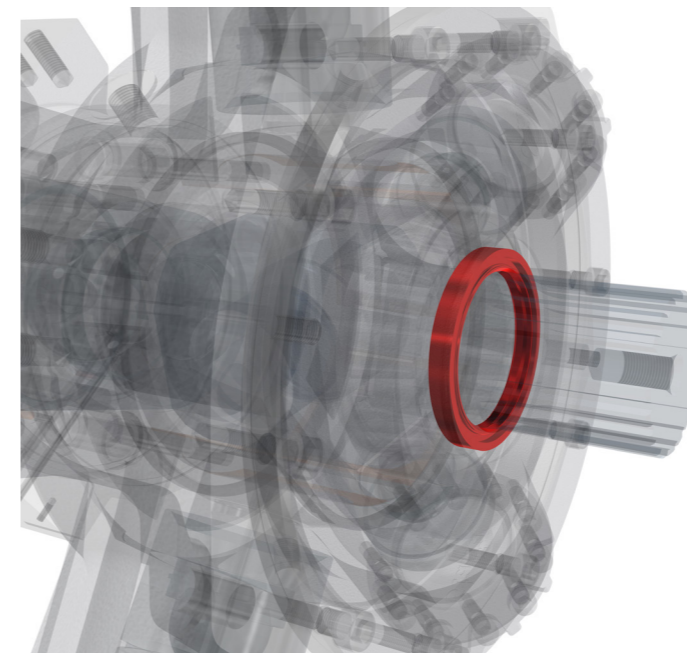

Description:

- > 10 bar rated
- > Recommended for cold climates
- > Rugged aluminium construction

Technical Information

Where crankcase pressure will be higher than 3.5 bar, the high pressure shaft seal should be selected.

Case pressure	≤ 10bar
Non-operating temperature limits	Below -30°C and above 120°C
Minimum operating temperature	-15°C
Maximum operating temperature	80°C
Minimum viscosity	2,000cSt
Maximum viscosity	150cSt

Applicable to:

HMB 030	HMB 030 -F(M)3/SM3	HMB 045	HMB 045 -F(M)3/SM3	HMB 060/080	HMB 100	HM(HD)B 125	HM(HD)B 150/200	HM(HD)B 270	HM(HD)B 325	HMHDB 400	HMB 500
●	●	●	●	●	●	●	●	●	●	●	●

Please contact Kawasaki to order this feature.

2-12 Special Features (cont)

◆ Improved Shaft Seal Life

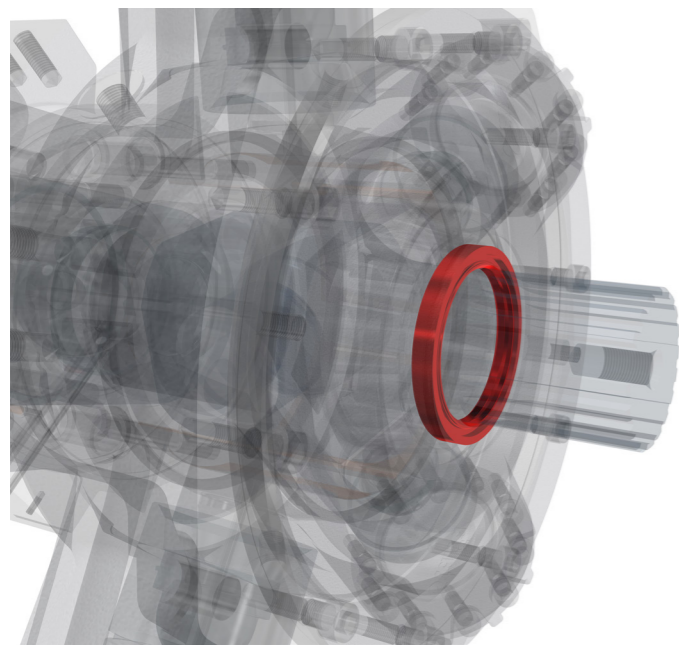

Description:

- > Stainless steel sleeve prevents corrosion
- > Improved wear resistance
- > Recommended for corrosive environments

Technical Information

A well-established method of increasing rotary seal life in corrosive environments is to fit a thin-walled, stainless steel sleeve to the rotating shaft to provide a corrosion-resistant, wear-resistant counterface surface for the seal to run against. All HMB motors can be fitted with such sleeves upon request.

Sleeve material	A304/301 Stainless Steel
Sleeve surface finish	R _a 0.25 to 0.5µm (10 to 20µin)

Applicable to:

HMB 030	HMB 030 -F(M)3/SM3	HMB 045	HMB 045 -F(M)3/SM3	HMB 060/080	HMB 100	HM(HD)B 125	HM(HD)B 150/200	HM(HD)B 270	HM(HD)B 325	HMHDB 400	HMB 500
●	●	●	●	●	●	●	●	●	●	●	●

Please contact Kawasaki to order this feature.

2-12 Special Features (cont)

◆ Improved Cavitation Resistance

Description:

- > Recommended for overrunning applications
- > Protects against seal damage for short periods of operation in vacuum inlet conditions.

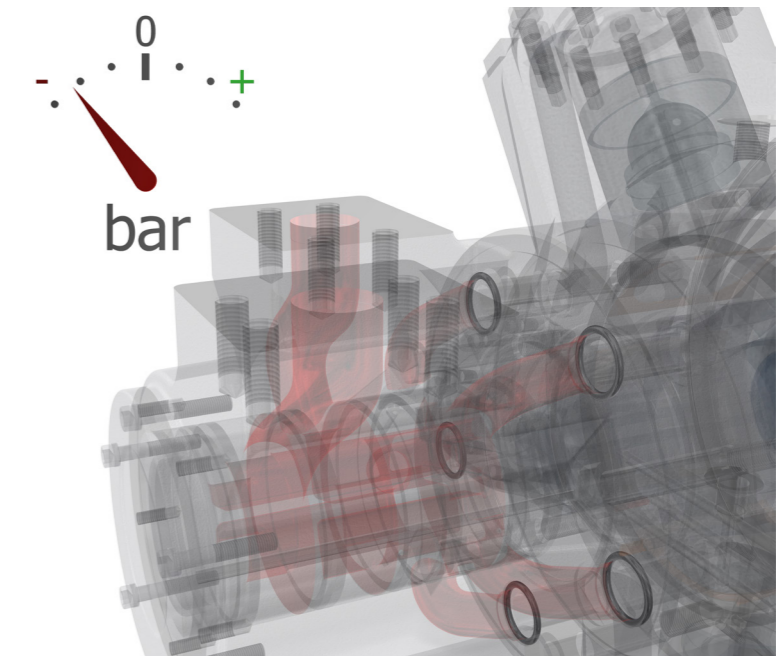

Cavitation can occur due to many different factors. Although it is not possible to make the HMB motor resistant to cavitation, certain features can be added to improve the motor's resistance to short periods of lost port pressure.

In applications where the HMB motor can be driven (like a pump) a risk arises that insufficient fluid will be provided to maintain a positive pressure at both main ports of the motor causing cavitation. The results of extended running at these conditions can be catastrophic to the motor's function.

The improved cavitation resistance feature should be considered where:

- Overrunning conditions may occur (load driving the motor)
- Loss of main port pressure while motor is rotating

NOTE:

This feature comes as standard on monobloc HMB motors (HMB030, HMB045).

Applicable to:

HMB 030	HMB 030 -F(M)3/SM3	HMB 045	HMB 045 -F(M)3/SM3	HMB 060/080	HMB 100	HM(HD)B 125	HM(HD)B 150/200	HM(HD)B 270	HM(HD)B 325	HMHDB 400	HMB 500
○	○	○	●	●	●	●	●	●	●	●	●

Please contact Kawasaki to order this feature.

2-12 Special Features (cont)

◆ Increased Starting Torque

Description:

- > Optimised for high break-out torque
- > Recommended for low speed operation
- > Improved service life for low speed applications

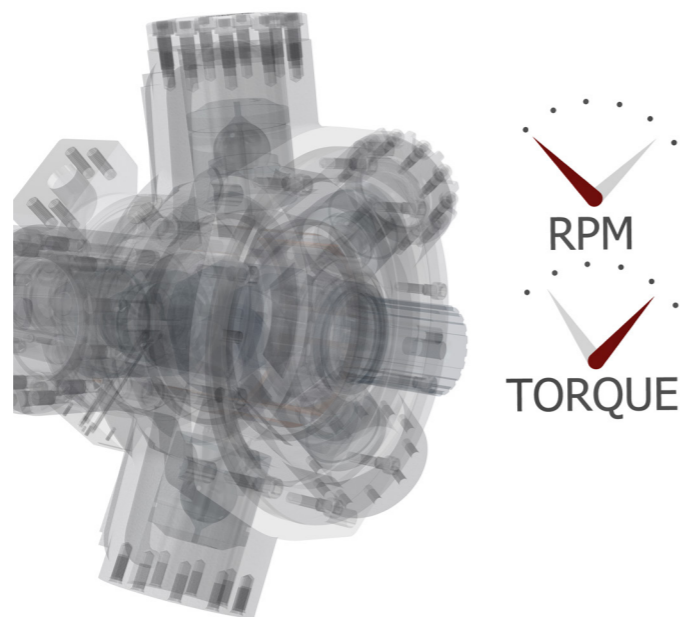

Technical Information

If an application demands the drive motor be run at speeds of less than 10 rpm for most of the duty cycle, or involves frequent start/stop or forward/reverse operation, the Staffa HMB motor range has it covered.

By optimising the HMB motor's design for low speeds, it is possible to increase the break out torque and low speed mechanical efficiency performance.

All figures given in Section 2-1 Performance Data are still valid when selecting this feature.

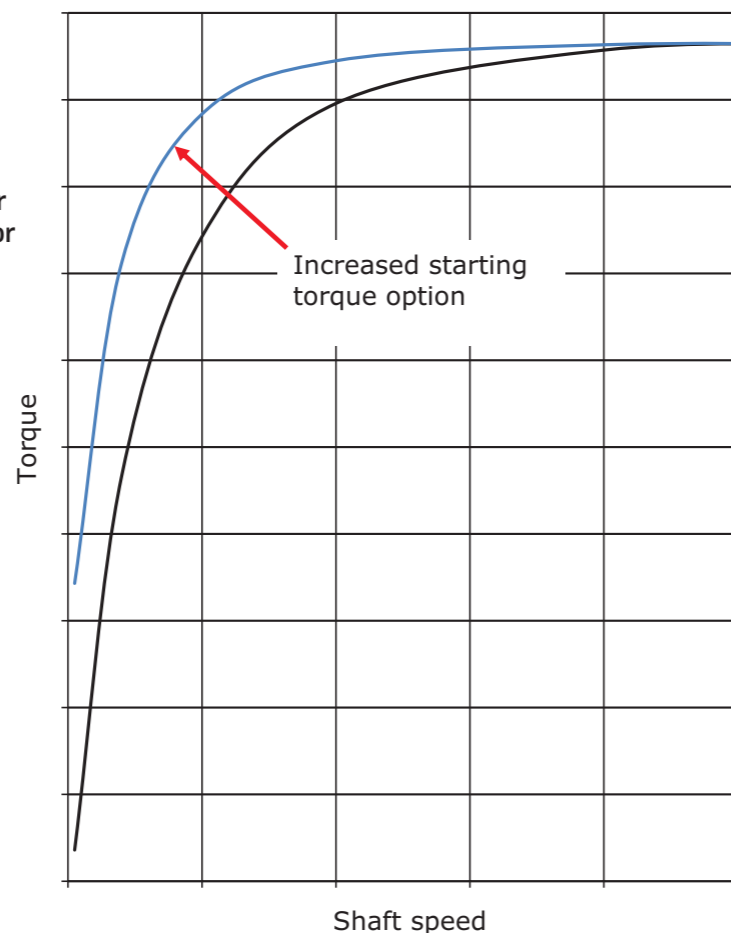

2-12 Special Features (cont)

◆ Increased Starting Torque (cont)

Volumetric Performance

In order to achieve increased torque at low speeds the volumetric characteristics of the motor performance are changed.

When calculating leakage and volumetric efficiency use the constants shown here in place of those given for the standard motor in Section 2-1.

Motor Type	Geometric Displacement	Zero Speed Constant	Speed Constant	Creep Speed Constant	Crankcase Leakage Constant
	cc/rev	K1	K2	K3	K4
HMB030	442	8.62	51.80	17.54	8.06
HMB030 2-piece	492	8.51	57.67	19.37	8.06
HMB045	740	3.93	43.36	12.80	9.23
HMB060	983	9.19	29.91	9.95	9.35
HMB080	1,344	9.18	21.62	7.39	9.31
HMB100	1,639	9.10	19.90	5.97	9.35
HM(HD)B125	2,050	9.53	11.45	4.88	8.82
HM(HD)B150	2,470	9.09	9.98	4.02	8.86
HM(HD)B200	3,087	10.00	14.99	3.20	8.86
HM(HD)B270	4,310	13.63	21.16	3.11	12.26
HM(HD)B325	5,310	13.60	18.21	2.52	12.26
HMHDB400	6,800	19.00	10.18	2.73	17.29

Applicable to:

HMB 030	HMB 030 -F(M)3/ SM3	HMB 045	HMB 045 -F(M)3/ SM3	HMB 060/ 080	HMB 100	HM(HD)B 125	HM(HD)B 150/200	HM(HD)B 270	HM(HD)B 325	HMHDB 400	HMB 500
●	●	●	●	●	●	●	●	●	●	●	○

Please contact Kawasaki to order this feature.

2-12 Special Features (cont)

◆ Anti-Clockwise Rotation

Description:

- > Reduce installation complexity
- > Standardise equipment designs

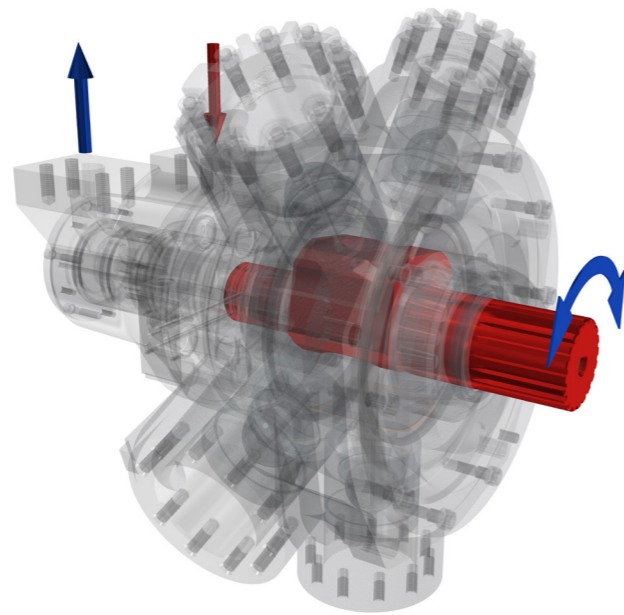

Technical Information

All HMB motors can be specified with an anti-clockwise rotation valve configuration. All performance and volumetric characteristics remain unchanged.

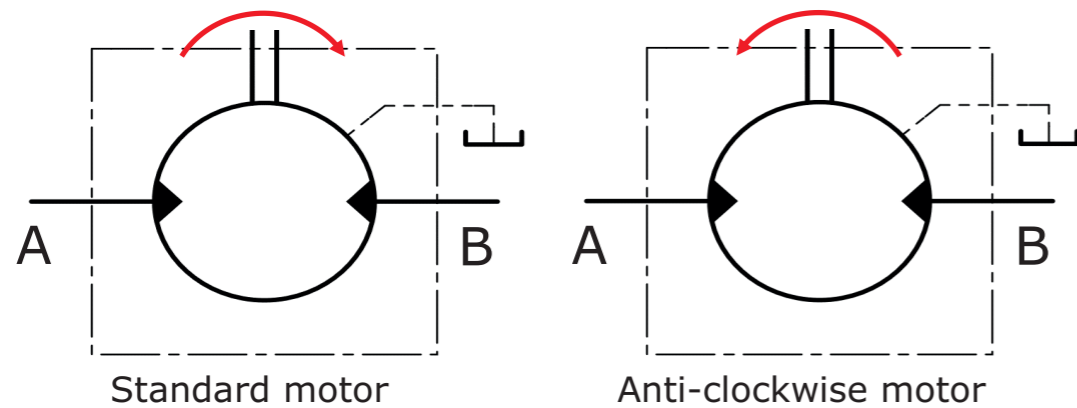

Applicable to:

HMB 030	HMB 030 -F(M)3/ SM3	HMB 045	HMB 045 -F(M)3/ SM3	HMB 060/ 080	HMB 100	HM(HD)B 125	HM(HD)B 150/200	HM(HD)B 270	HM(HD)B 325	HMHDB 400	HMB 500
●	●	●	●	●	●	●	●	●	●	●	●

Please contact Kawasaki to order this feature.

2-12 Special Features (cont)

◆ Thermal Shock Resistance

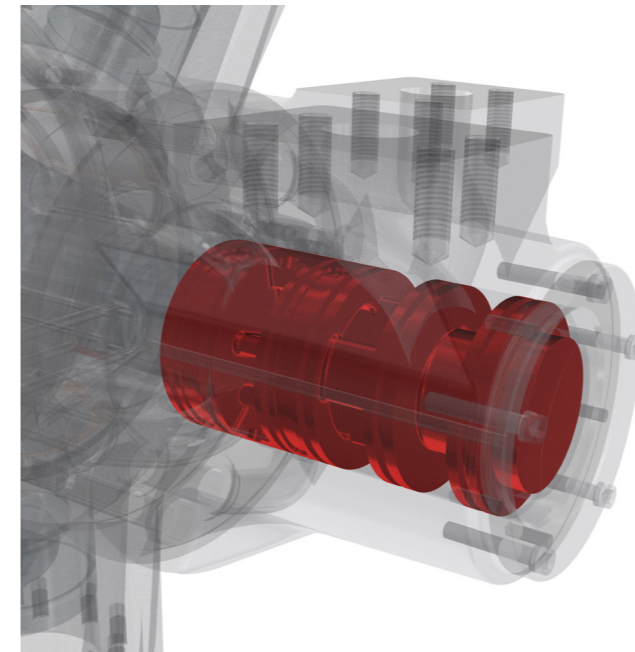

Description:

- > Recommended for cold climates
- > Optimised for start-up in freezing temperatures
- > Engineered for total peace of mind

Technical Information

Starting up a cold system with warm hydraulic fluid is a known cause of heavy wear and potential seizure of hydraulic machinery. To minimise this potential risk, the HMB motor can be configured to combat thermal shocks to give complete peace of mind when operating in very cold climates.

Volumetric Performance

In order to provide thermal shock resistance the volumetric characteristics of the motor performance are changed. When calculating leakage and volumetric efficiency use the constants shown in Section 2-12 in place of those given for the standard motor in Section 2-1.

All figures given in Section 2-1 Performance Data are still valid when selecting this feature.

Note:

When operating at low temperature, consideration must be given to the guidance notes in Section 2-8 Motor Operation at Low Temperature.

2-12 Special Features (cont)

◆ Thermal Shock Resistance (cont)

Motor Type	Geometric Displacement	Zero Speed Constant	Speed Constant	Creep Speed Constant	Crankcase Leakage Constant
	cc/rev	K1	K2	K3	K4
HMB060	983	3.72	29.91	4.39	1.88
HMB080	1,344	3.71	21.62	3.32	1.84
HMB100	1,600	3.63	19.90	2.63	1.88
HM(HD)B125	2,050	4.41	11.45	2.21	1.35
HM(HD)B150	2,470	3.97	9.98	1.81	1.39
HM(HD)B200	3,087	4.88	14.99	1.43	1.39
HM(HD)B270	4,310	5.52	21.16	1.23	1.80
HM(HD)B325	5,310	5.49	18.21	0.99	1.80
HMHDB400	6,800	6.41	10.18	0.88	2.35

Applicable to:

HMB 030	HMB 030 -F(M)3/ SM3	HMB 045	HMB 045 -F(M)3/ SM3	HMB 060/ 080	HMB 100	HM(HD)B 125	HM(HD)B 150/200	HM(HD)B 270	HM(HD)B 325	HMHDB 400	HMB 500
○	○	○	●	●	●	●	●	●	●	●	○

Please contact Kawasaki to order this feature.

2-12 Special Features (cont)

◆ Drain Port Adaptors

Description:

- > Improves manufacturing logistics
- > Motor supplied ready for connection to ½" BSPP male fitting

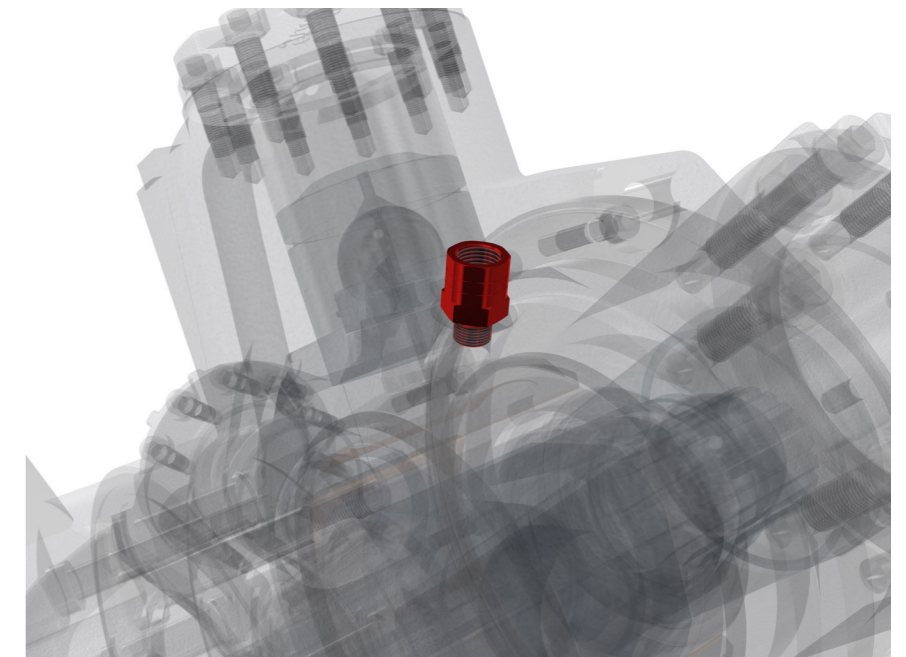

Technical Information

Motor Type	Adaptor Supplied
HMB030	⅜" BSP to ½" BSPP
HMB045	⅜" BSP to ½" BSPP
HMB045-F(M)3/SM3	¾" UNF 2B to ½" BSPP
HMB060	¾" UNF 2B to ½" BSPP
HMB080	¾" UNF 2B to ½" BSPP
HMB100	¾" UNF 2B to ½" BSPP
HM(HD)B125	¾" UNF 2B to ½" BSPP

Motor Type	Adaptor Supplied
HM(HD)B150	¾" UNF 2B to ½" BSPP
HM(HD)B200	¾" UNF 2B to ½" BSPP
HM(HD)B270	¾" UNF 2B to ½" BSPP
HM(HD)B325	¾" UNF 2B to ½" BSPP
HMHDB400	¾" UNF 2B to ½" BSPP
HMB500	¾" UNF 2B to ½" BSPP

One or two drain adaptors can be supplied.

Applicable to:

HMB 030	HMB 030 -F(M)3/ SM3	HMB 045	HMB 045 -F(M)3/ SM3	HMB 060/ 080	HMB 100	HM(HD)B 125	HM(HD)B 150/200	HM(HD)B 270	HM(HD)B 325	HMHDB 400	HMB 500
●	●	●	●	●	●	●	●	●	●	●	●

Please contact Kawasaki to order this feature.

2-12 Special Features (cont)

◆ Mounting Hole Diameter

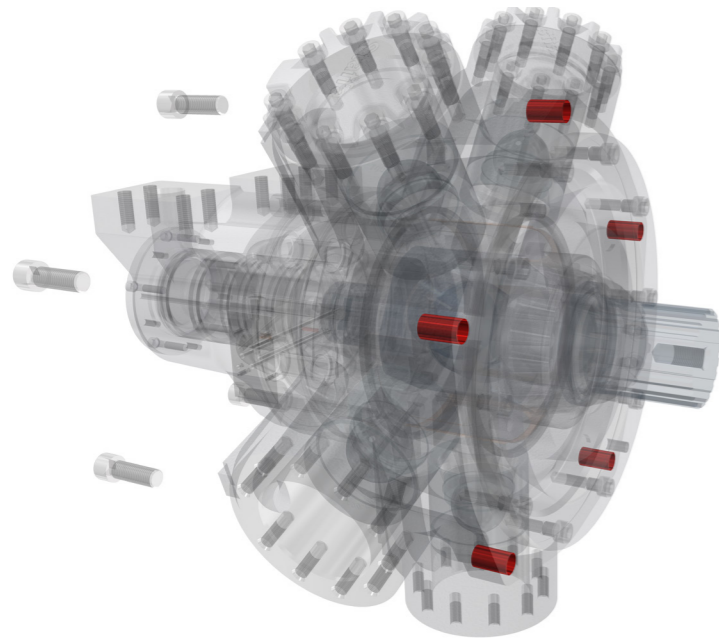

Description:

- > Matching mounting holes to bolts
- > $\Phi 21\text{mm}$ and $\Phi 22\text{mm}$ options available

Technical Information

In different markets, different bolt standards are adopted which may not be best suited to the standard $\Phi 20\text{mm}$ mounting hole diameter on the HMB motors. To give a correct fit and optimum installation, $\Phi 21\text{mm}$ or $\Phi 22\text{mm}$ holes can be selected on larger frame sizes.



Applicable to:

HMB 030	HMB 030 -F(M)3/SM3	HMB 045	HMB 045 -F(M)3/SM3	HMB 060/080	HMB 100	HM(HD)B 125	HM(HD)B 150/200	HM(HD)B 270	HM(HD)B 325	HMHDB 400	HMB 500
○	○	○	○	●	●	●	●	●	●	●	●

Please contact Kawasaki to order this feature.

2-12 Special Features (cont)

◆ Marine Specification Primer Paint

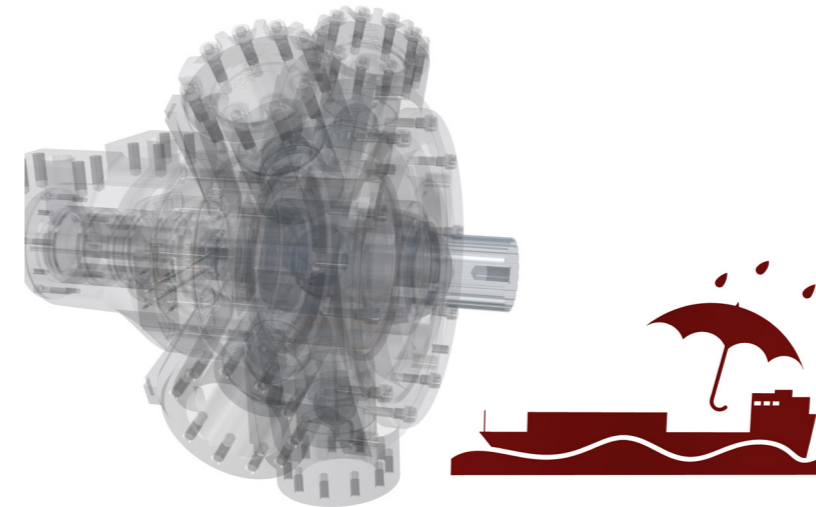

Description:

- > Improves corrosion and water resistance of the finishing system
- > Excellent adhesion strength
- > Recommended for marine applications

Technical Information

Colour	Red oxide
Type	Single pack epoxy etching primer
Standard	BS 3900 part A 8
Dry film thickness	> 12 μm

Applicable to:

HMB 030	HMB 030 -F(M)3/SM3	HMB 045	HMB 045 -F(M)3/SM3	HMB 060/080	HMB 100	HM(HD)B 125	HM(HD)B 150/200	HM(HD)B 270	HM(HD)B 325	HMHDB 400	HMB 500
●	●	●	●	●	●	●	●	●	●	●	●

Please contact Kawasaki to order this feature.

2-12 Special Features (cont)

Tj speed sensor technical specification

The Tj speed sensor is a hall effect dual channel speed probe that can provide feedback of both speed and direction.

- Signal Outputs: Square wave plus directional signal
- Power Supply: 8 to 32V @ 40mA
- Protection Class: IP68
- Output Frequency: 16 pulses/revolution

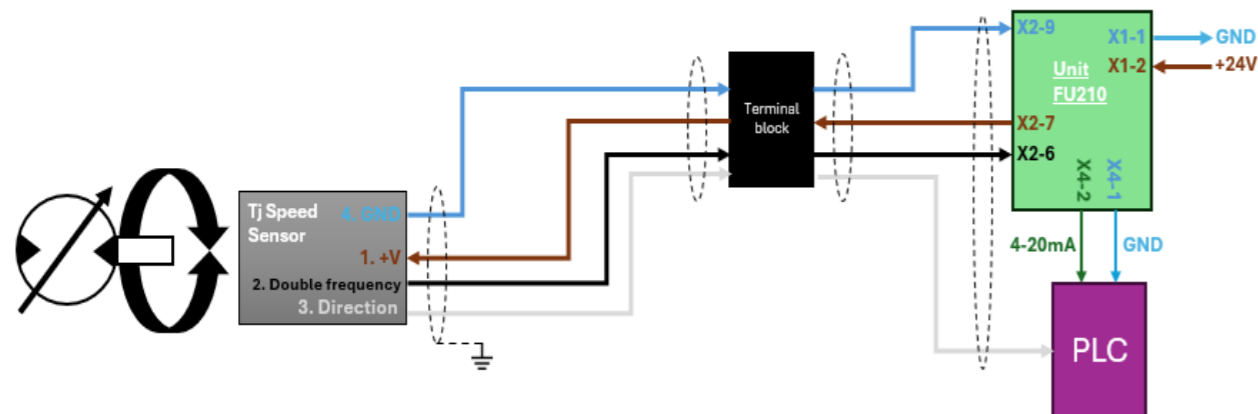
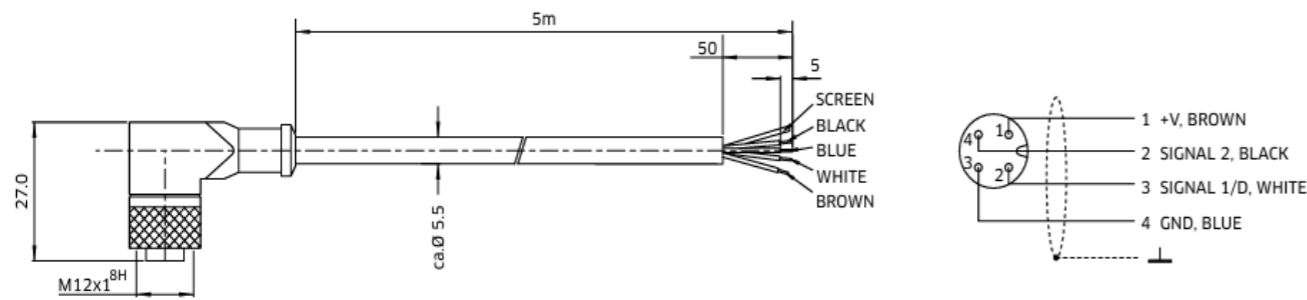
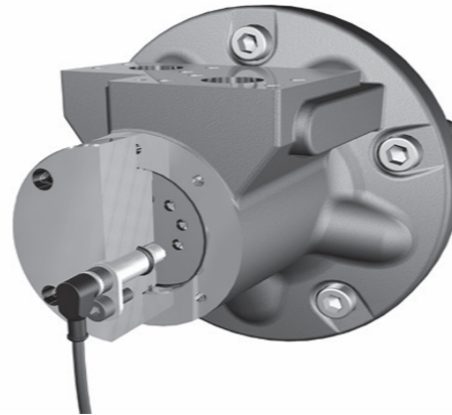

2-12 Special Features (cont)

Ts readout option

The Ts option consists of the Tj speed sensor together with the optional FU210 output module.

The addition of the FU210 module provides a software configured single channel tachometer and relay with a /4-20mA analogue current output which comes pre-programmed with the motor.

For more in-depth information please contact KPM UK.

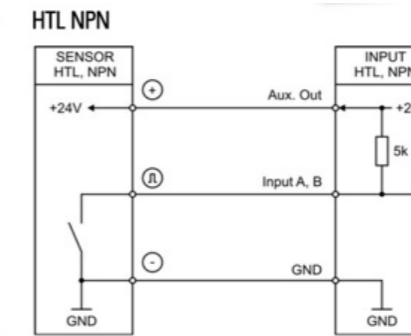
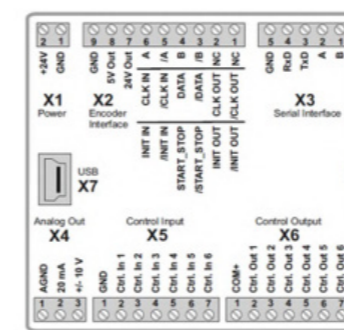

Installation Details

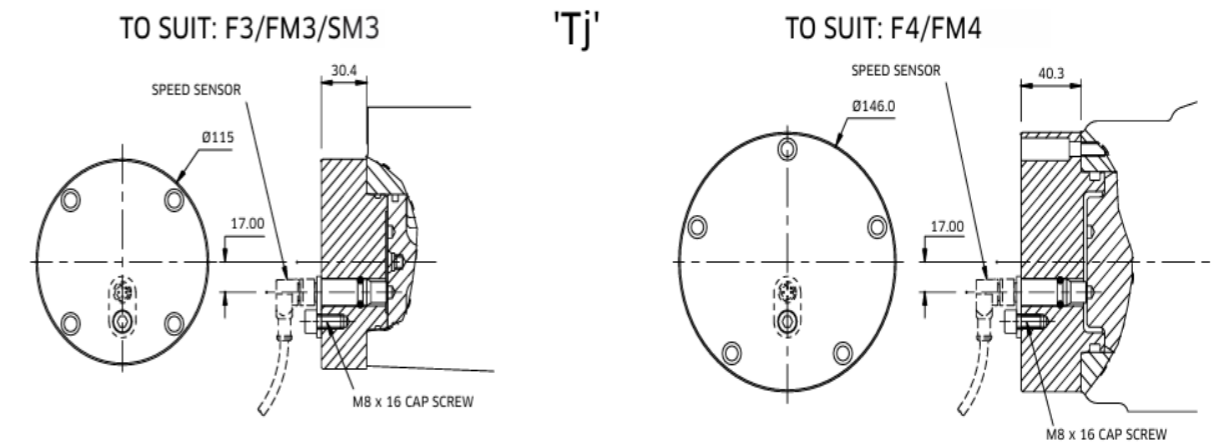

3 Dimensions

HMB MOTORS

HMB MOTORS

3-1 HMB030

◆ Monobloc - 'P', 'S' and 'Z' Shafts

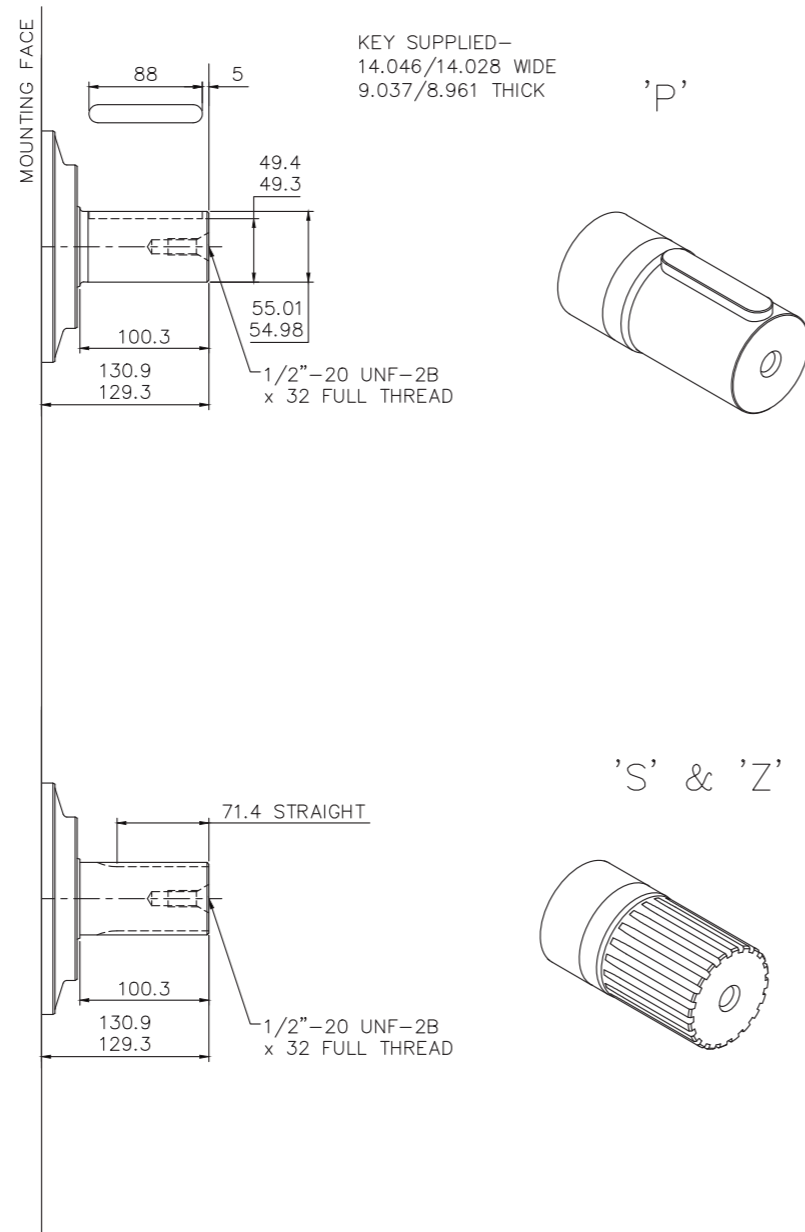

3-1 HMB030 (cont)

◆ 2 Piece - 'P', 'S' and 'Z' Shafts

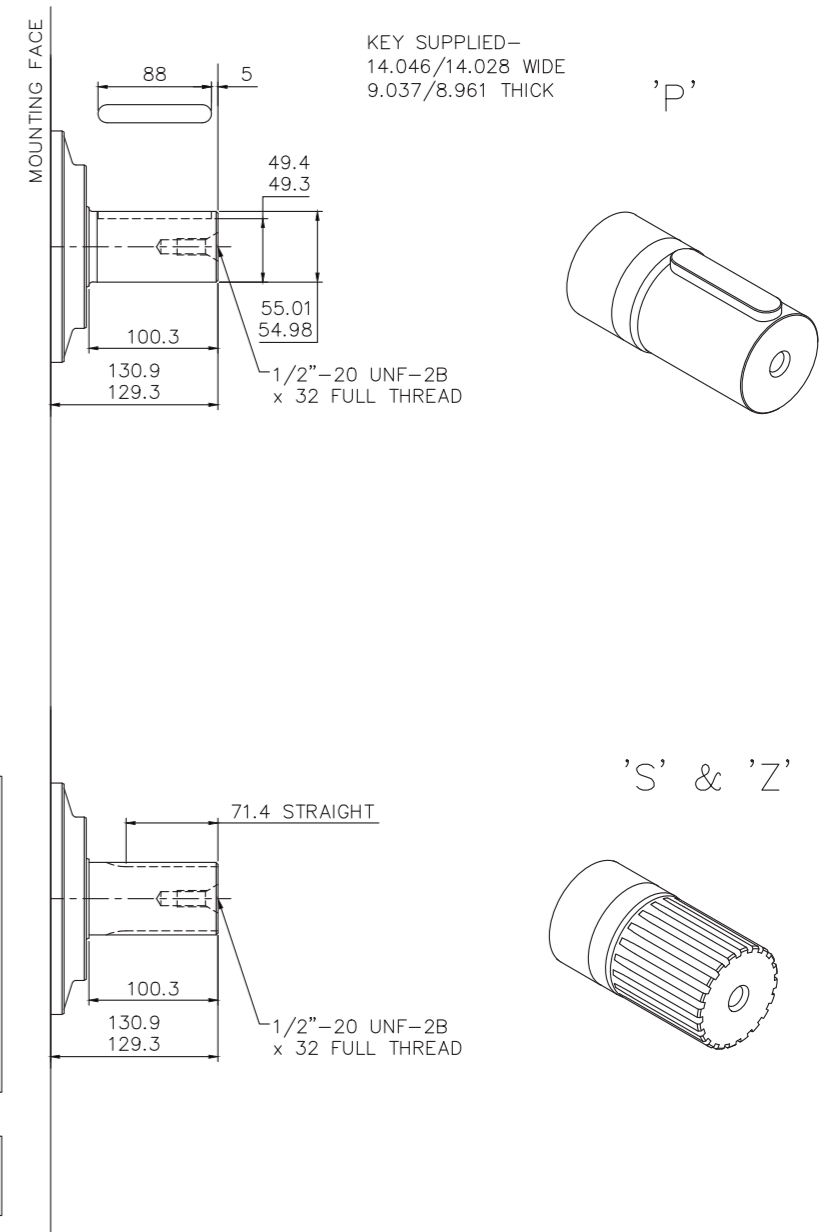

3-1 HMB030 (cont)

2 Piece - Installation

3/8" BSP x 17 FULL THREAD (CHOICE OF 3 POSITIONS) (2 NORMALLY PLUGGED)
 NOTE: - ENSURE ON INSTALLATION THAT DRAIN IS TAKEN FROM ABOVE MOTOR CENTRELINE.
 DO NOT EXCEED 12 DEPTH OF COUPLING IN TO DRAIN PORT

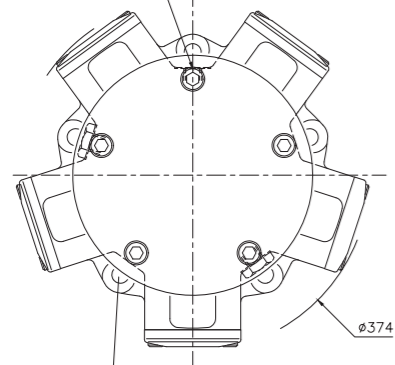

REVERSE PORT CONNECTIONS FOR OPPOSITE DIRECTION OF SHAFT ROTATION
 FLOW DIRECTION FOR ALL VLV HSG VARIANTS EXCEPT F2/FM2/SM3

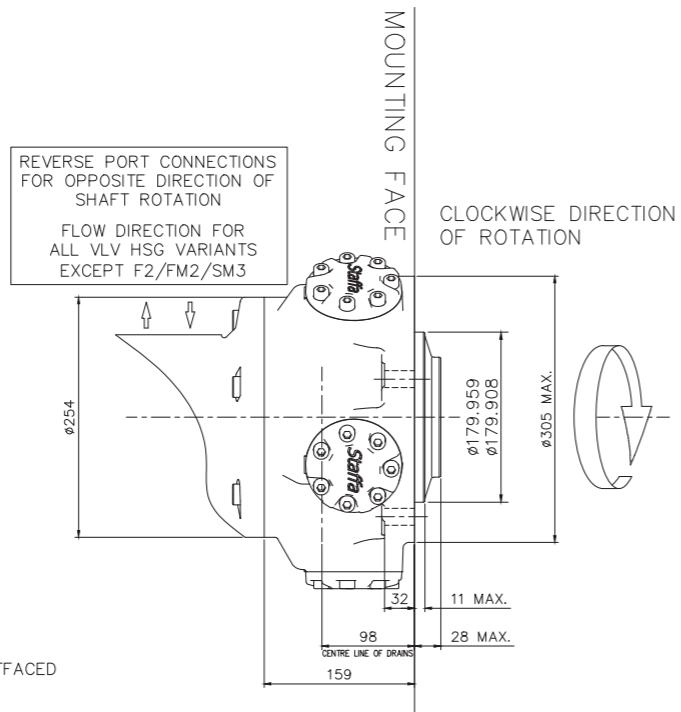

3-1 HMB030 (cont)

Monobloc - Side Port Installation

2 PORTS $\phi 25$ TO SUIT SAE CODE 61, 1" NOM. SPLIT FLANGE

PORT FLANGE BOLT TAPPING SIZE -
F: 3/8"-16 UNC-2B X 16 FULL THREAD DEPTH
FM: M10 X P1.5 X 16 FULL THREAD DEPTH

EXAMPLE FOR MODEL CODE.
 SIDE ENTRY MOTORCASE - HMB030/P/FM/21

3/8" BSP DRAIN
 NOTE: - ENSURE ON INSTALLATION THAT DRAIN IS CONNECTED TO PORT ABOVE MOTOR

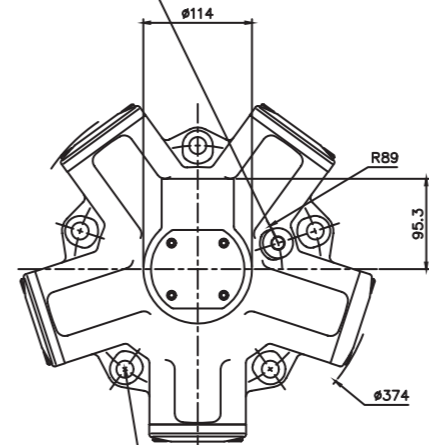

5 HOLES $\phi 18$ EQUI-SPACED AS SHOWN ON A $[260.1]$ P.C.D. SPOTFACED TO GIVE AN EFFECTIVE $\phi 35$.
 $\phi 0.15$

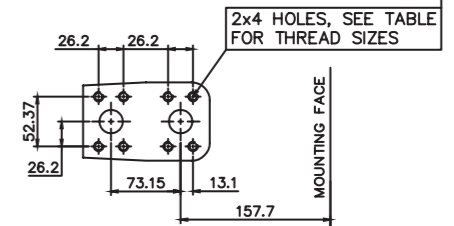

REVERSE PORT CONNECTIONS FOR OPPOSITE DIRECTION OF SHAFT ROTATION
 FLOW DIRECTION

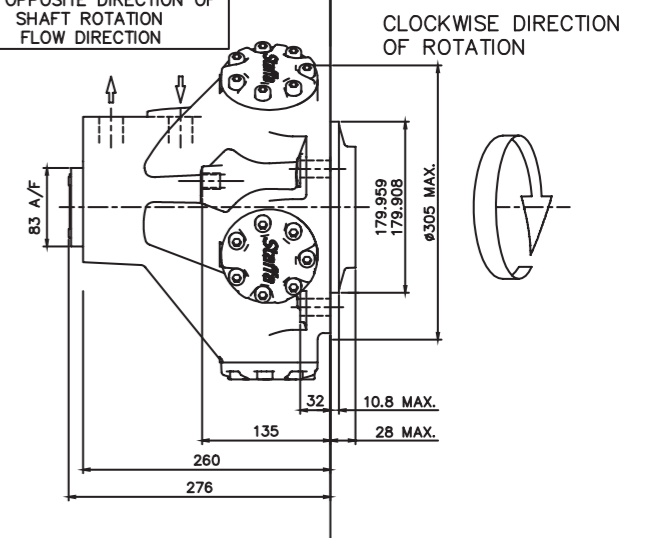

3-2 HMB045

◆ Monobloc - 'P', 'S' & 'Z' Shafts

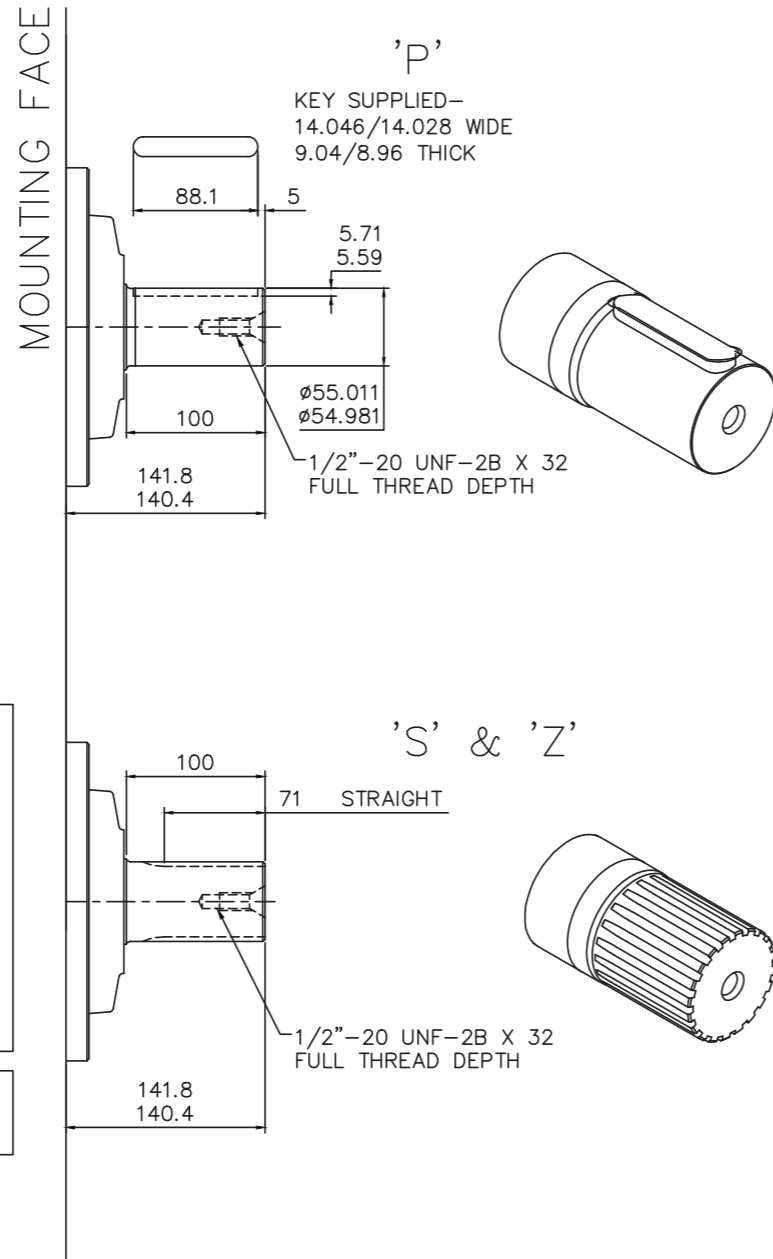

3-2 HMB045 (cont)

◆ 2 Piece - 'P', 'S', 'Z' & Q Shafts

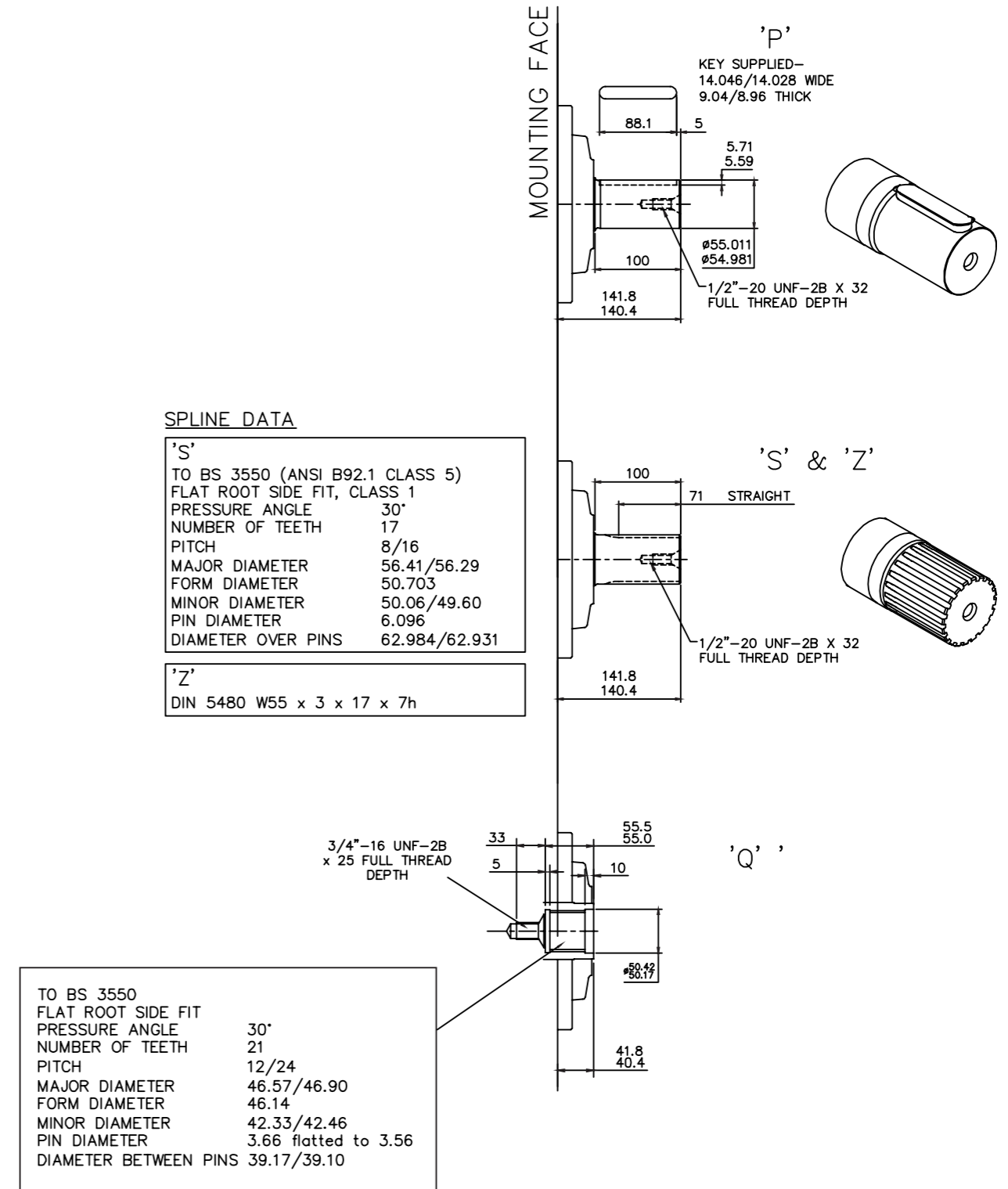

3-2 HMB045 (cont)

2 Piece - Installation

3/4"-16 UNF-2B DRAIN (CHOICE OF 3 POSITIONS)
(2 NORMALLY PLUGGED)
NOTE: - ENSURE ON INSTALLATION THAT DRAIN IS
TAKEN FROM ABOVE MOTOR CENTRELINE.
DO NOT EXCEED 12 DEPTH OF COUPLING
IN TO DRAIN PORT

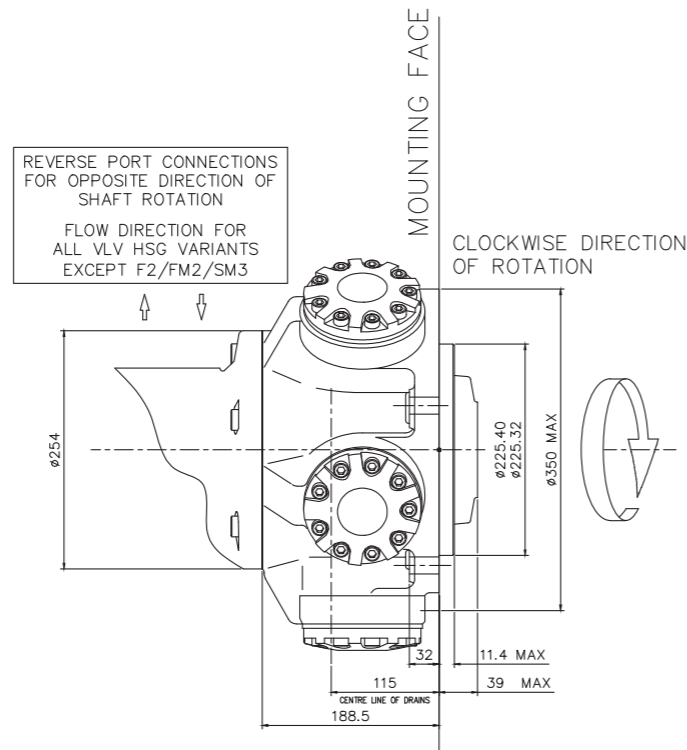
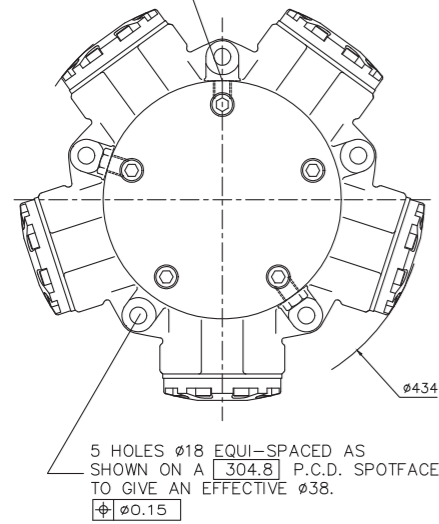

Monobloc - Installation

3/8" BSP DRAIN. 19mm DEEP, SPOTFACED $\phi 28$
(CHOICE OF 3 POSITIONS) (1 NORMALLY PLUGGED)
NOTE: - ENSURE ON INSTALLATION THAT DRAIN IS
TAKEN FROM ABOVE MOTOR CENTRELINE.

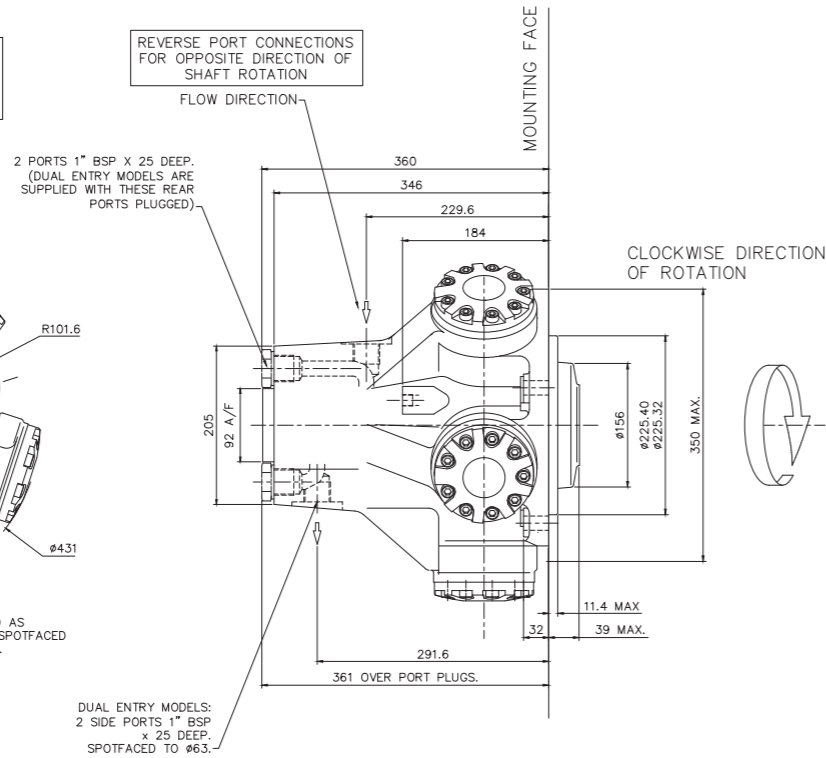
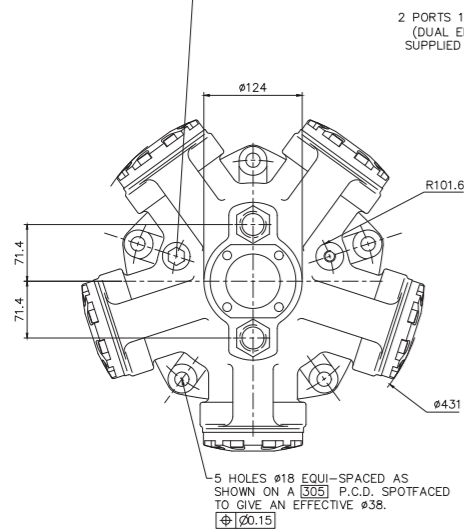

3-3 HMB060/080

'P', 'S' & 'Z' Shafts

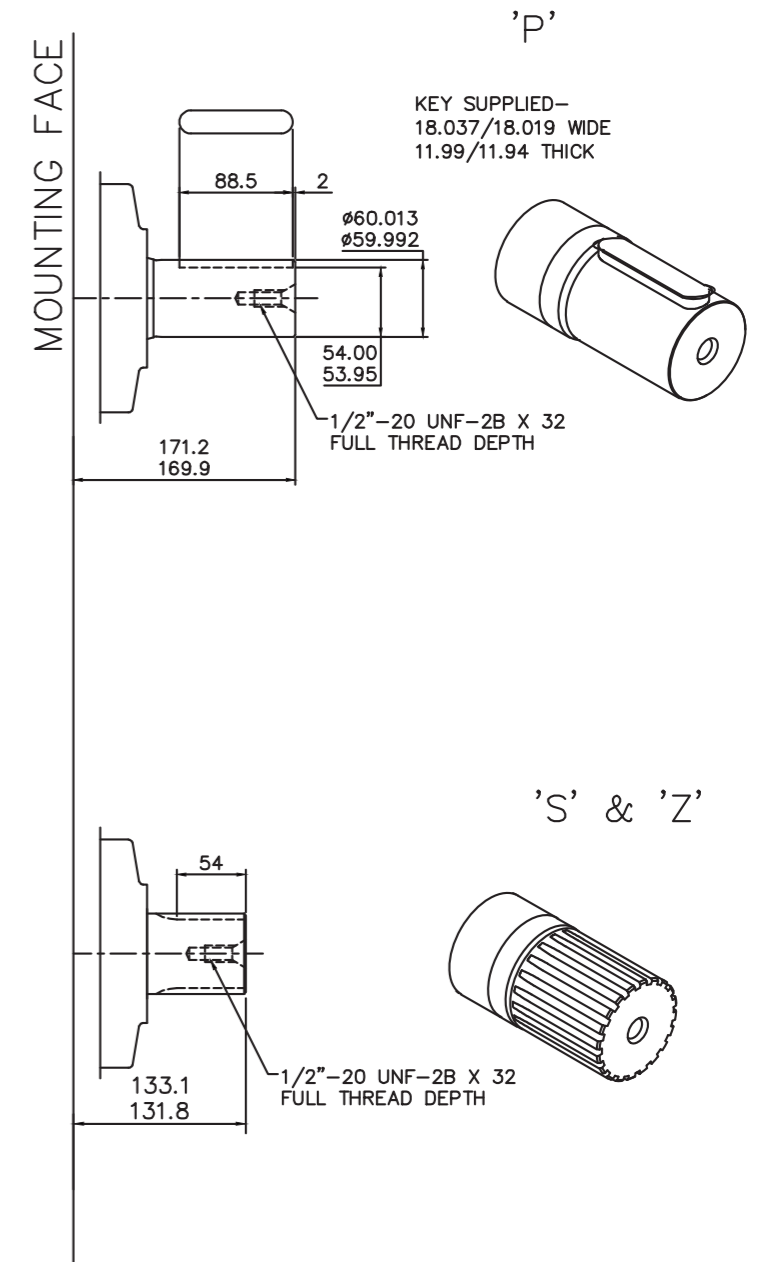

SPLINE DATA

'S'	
TO BS 3550 (ANSI B92.1 CLASS 5)	
FLAT ROOT SIDE FIT, CLASS 1	
PRESSURE ANGLE	30°
NUMBER OF TEETH	14
PITCH	6/12
MAJOR DIAMETER	62.553/62.425
FORM DIAMETER	55.052
MINOR DIAMETER	54.084/53.525
PIN DIAMETER	8.128
DIAMETER OVER PINS	71.593/71.544

'Z'	
DIN 5480 W70 x 3 x 30 x 22 x 7h	

3-3 HMB060/080 (cont)

◆ 'T' & 'Q' Shafts

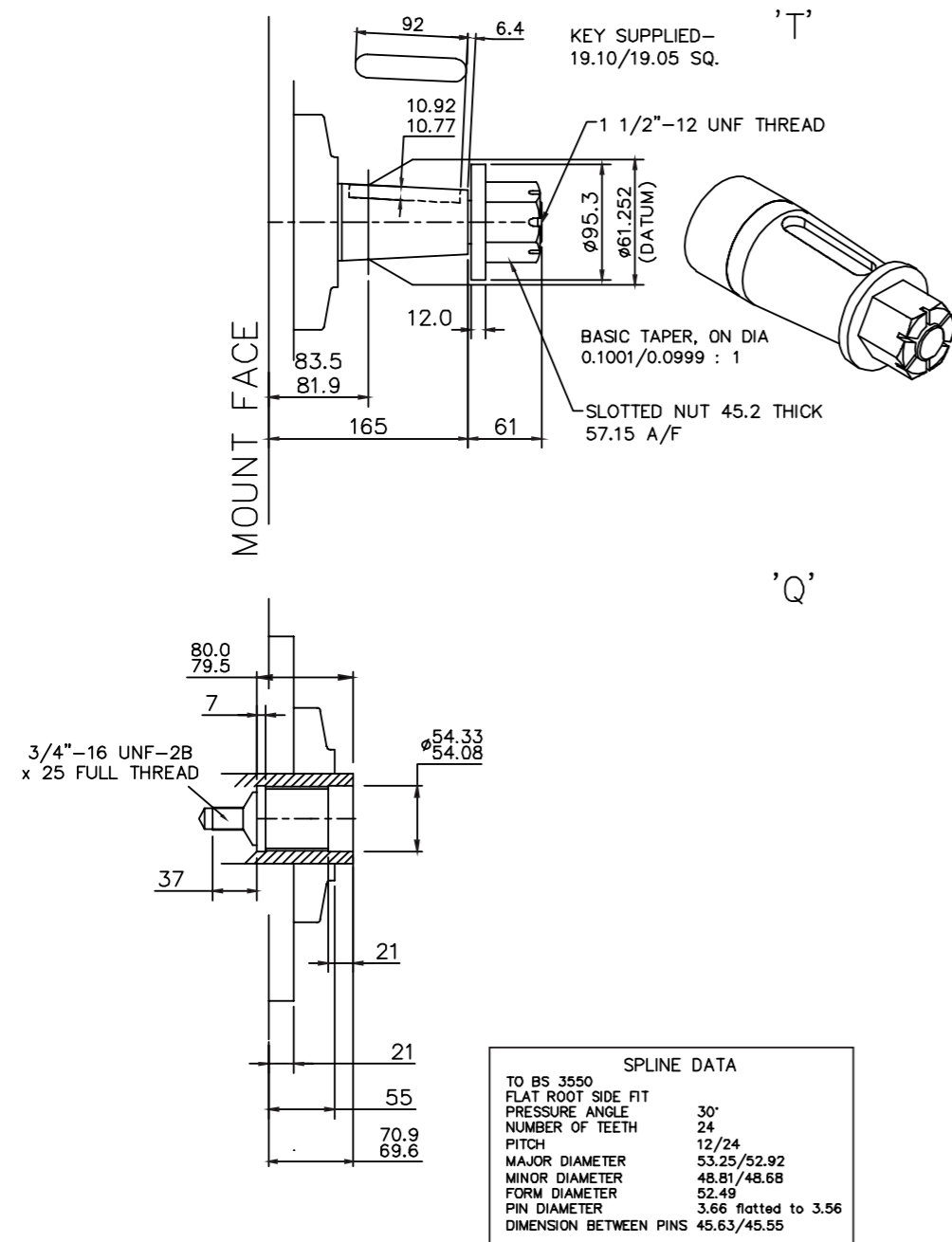

3-3 HMB060/080 (cont)

◆ Installation

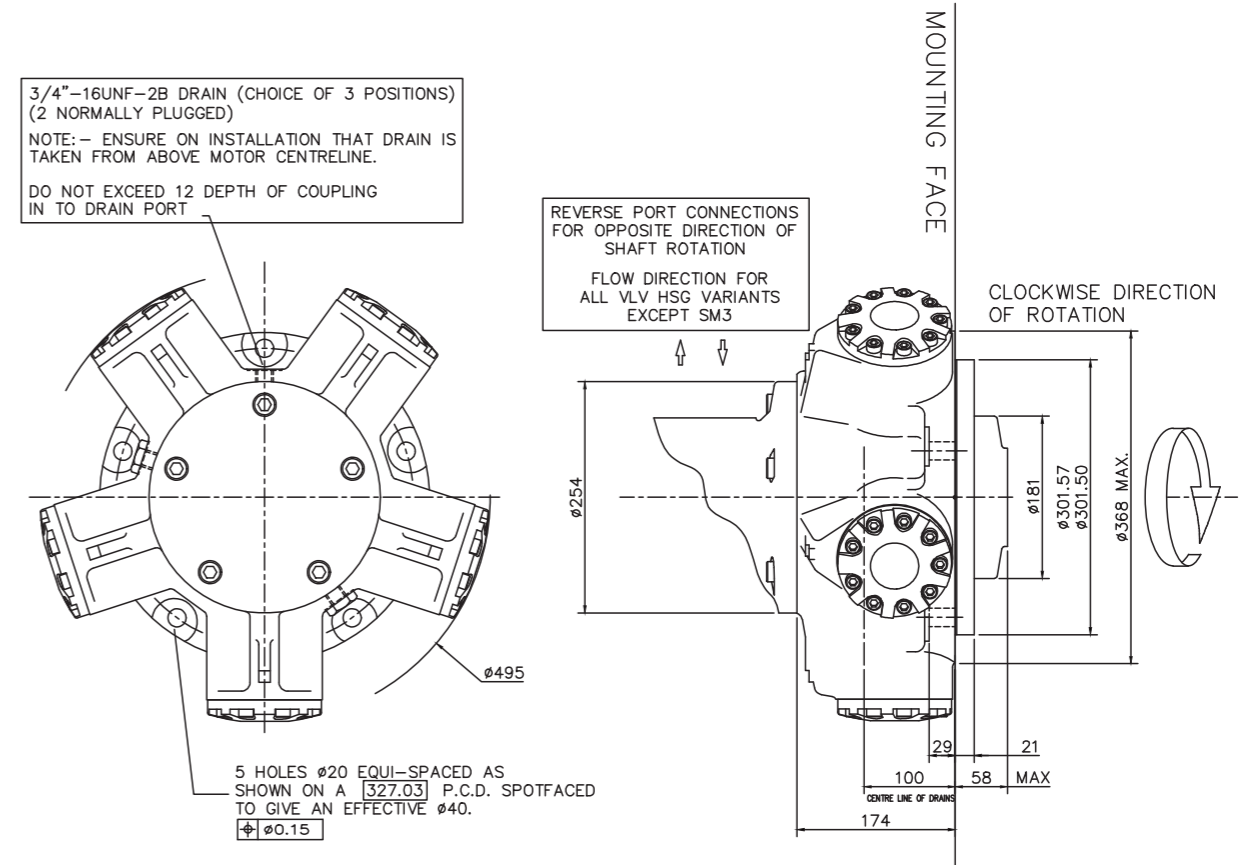

3-4 HMB100

◆ 'P', 'S' & 'Z' Shafts

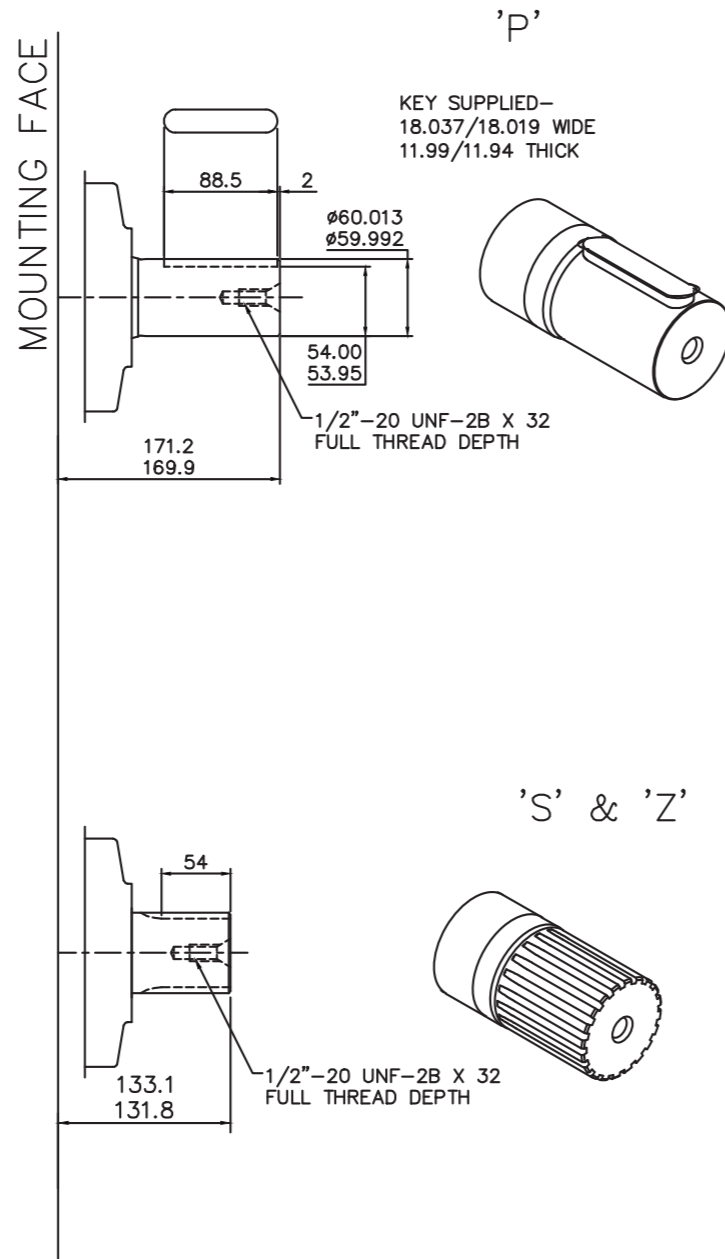

SPLINE DATA

'S'	
TO BS 3550 (ANSI B92.1 CLASS 5)	
FLAT ROOT SIDE FIT, CLASS 1	
PRESSURE ANGLE	30°
NUMBER OF TEETH	14
PITCH	6/12
MAJOR DIAMETER	62.553/62.425
FORM DIAMETER	55.052
MINOR DIAMETER	54.084/53.525
PIN DIAMETER	8.128
DIAMETER OVER PINS	71.593/71.544

'Z'	
DIN 5480 W70 x 3 x 30 x 22 x 7h	

3-4 HMB100 (cont)

◆ 'T' & 'Q' Shafts

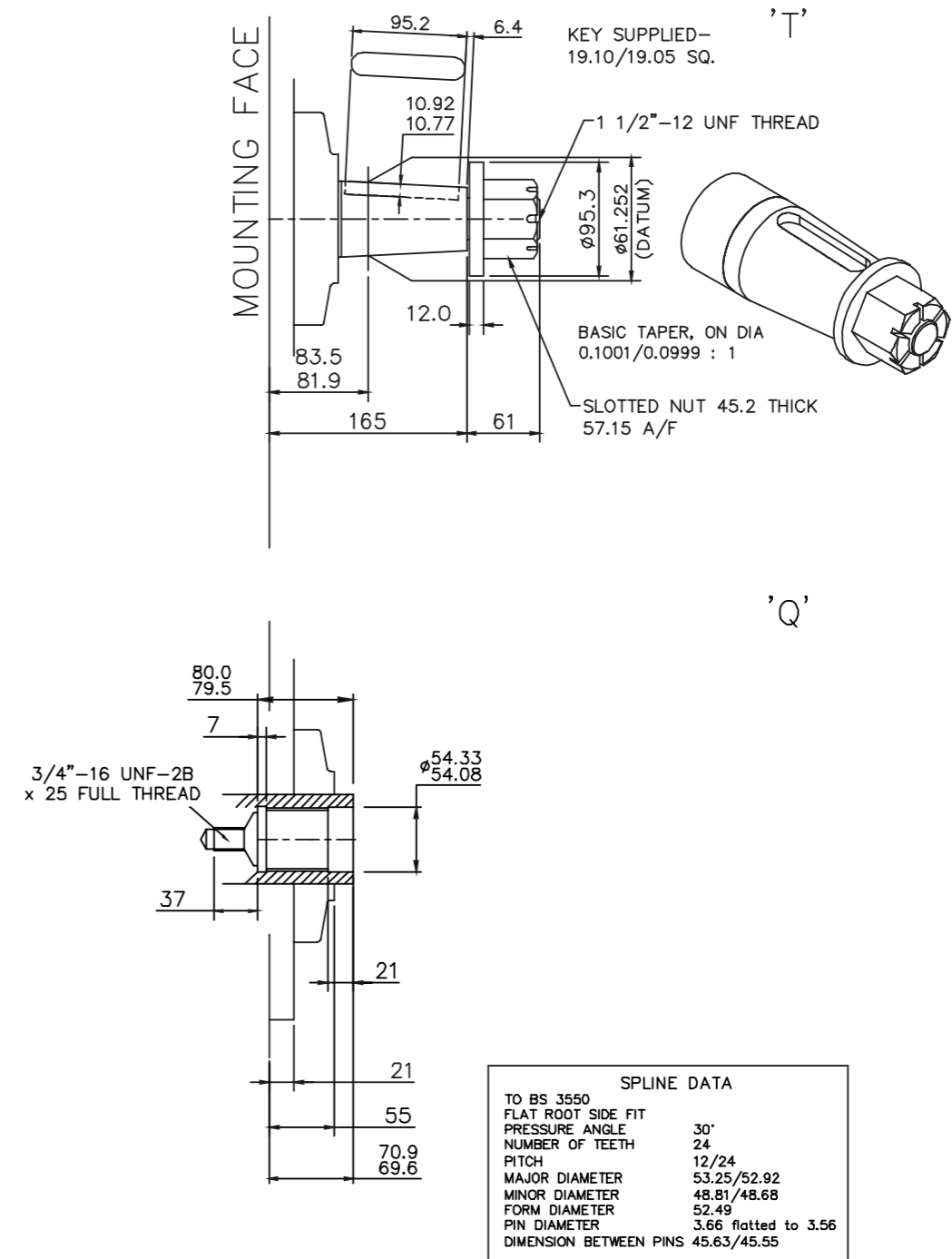

SPLINE DATA	
TO BS 3550	
FLAT ROOT SIDE FIT	
PRESSURE ANGLE	30°
NUMBER OF TEETH	24
PITCH	12/24
MAJOR DIAMETER	53.25/52.92
MINOR DIAMETER	48.81/48.68
FORM DIAMETER	52.49
PIN DIAMETER	3.66 flattened to 3.56
DIMENSION BETWEEN PINS	45.63/45.55

3-4 HMB100 (cont)

Installation

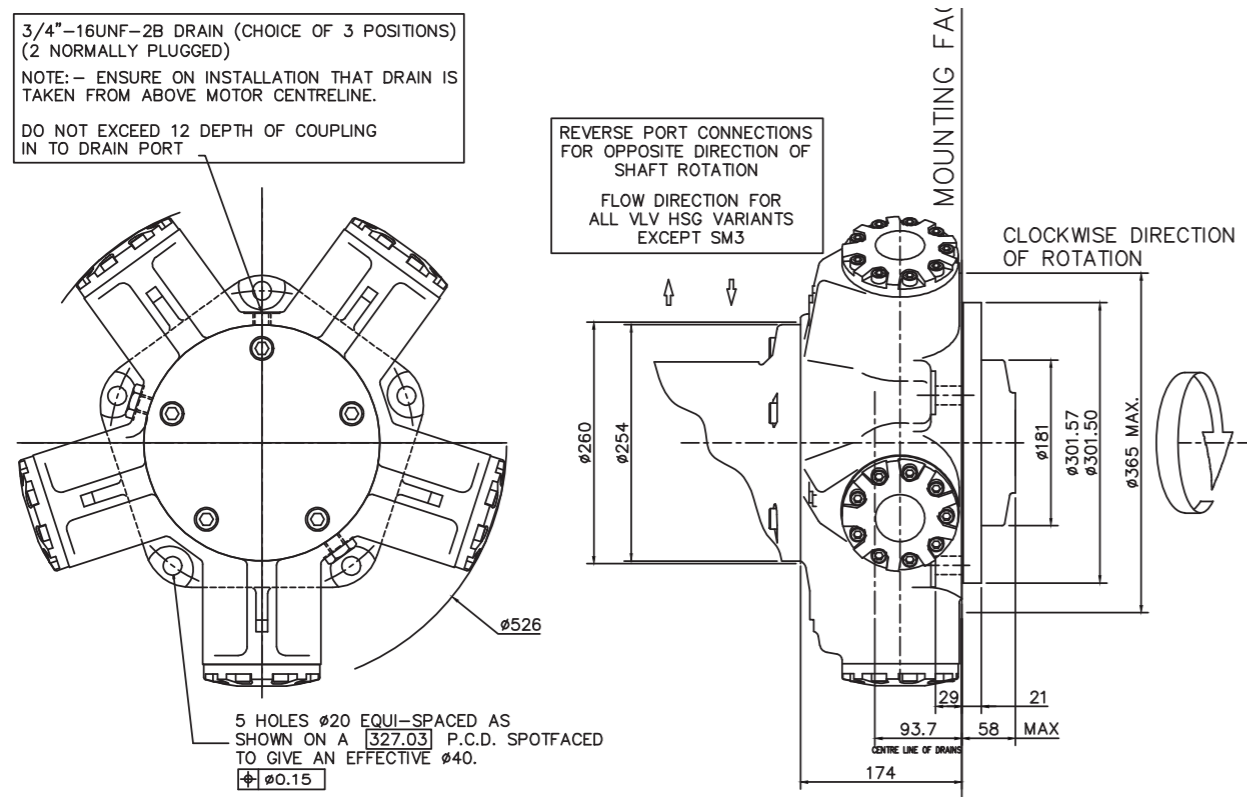

3-5 HM(HD)B125

HMB125 - 'P1', 'S3', 'S4' & 'Z3' Shafts

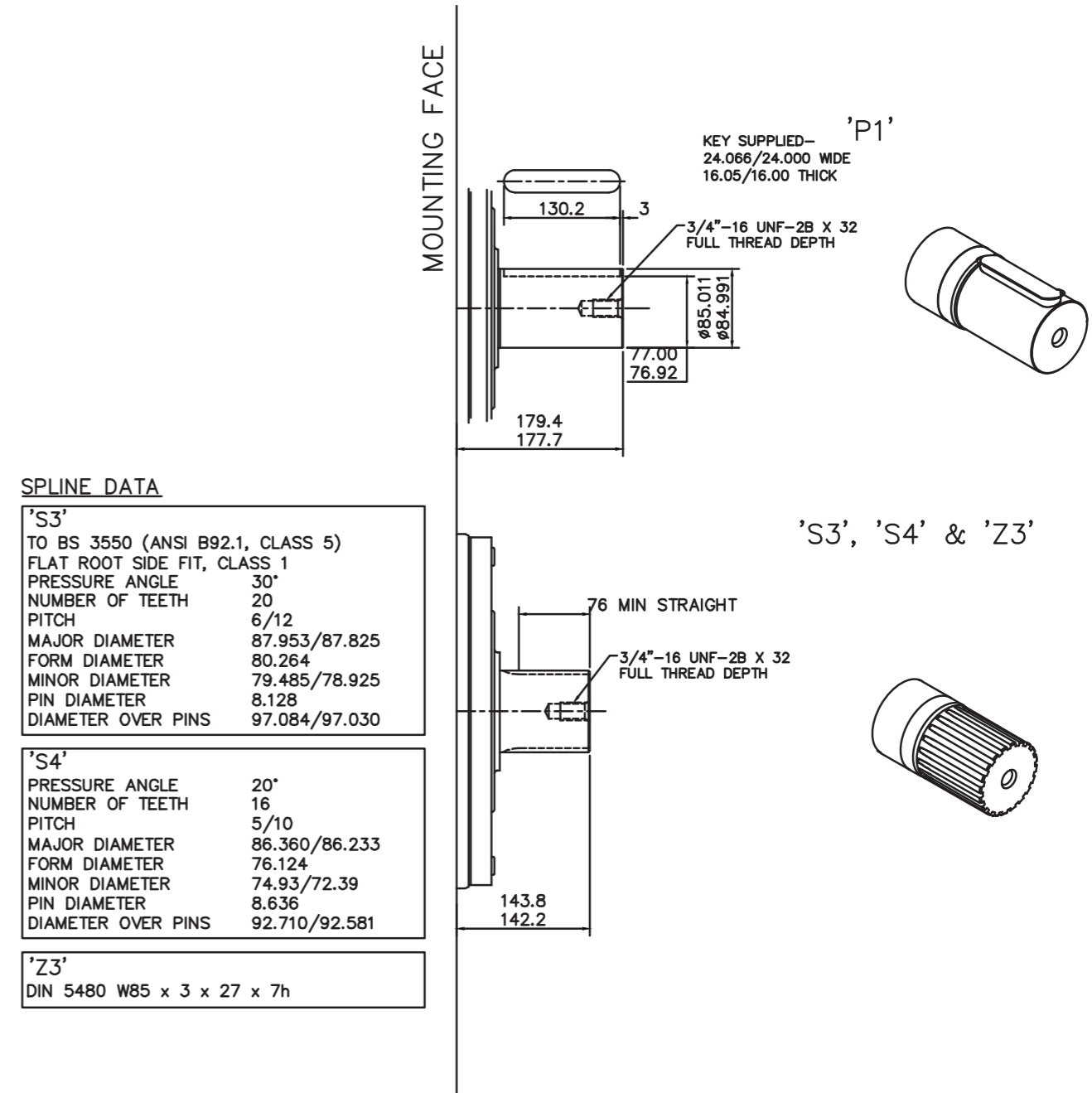

3-5 HM(HD)B125 (cont)

◆ HMB125 - 'T' & 'Q' Shafts

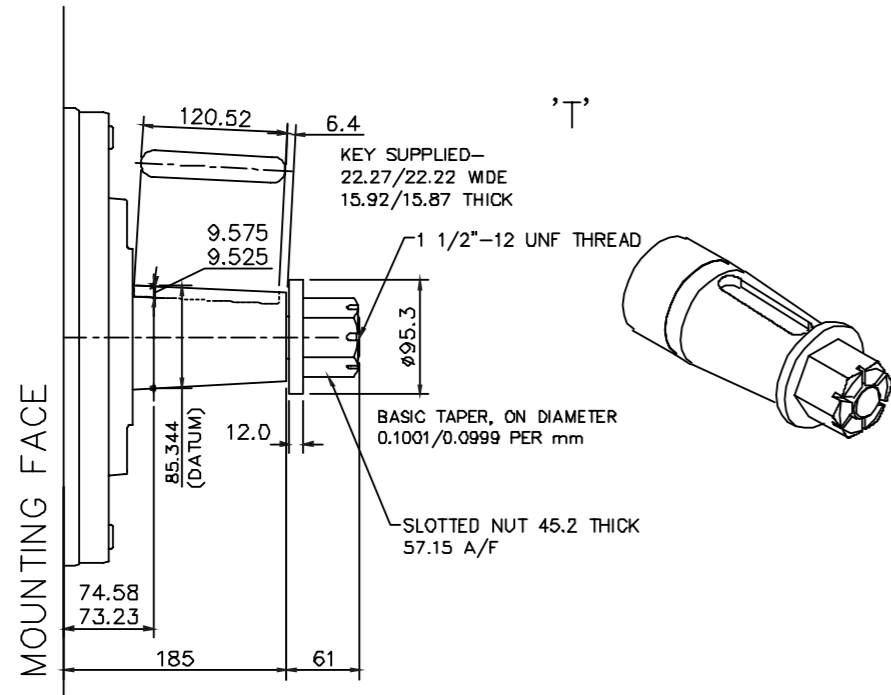

3-5 HM(HD)B125 (cont)

◆ HMHDB125 - 'P2' Shafts

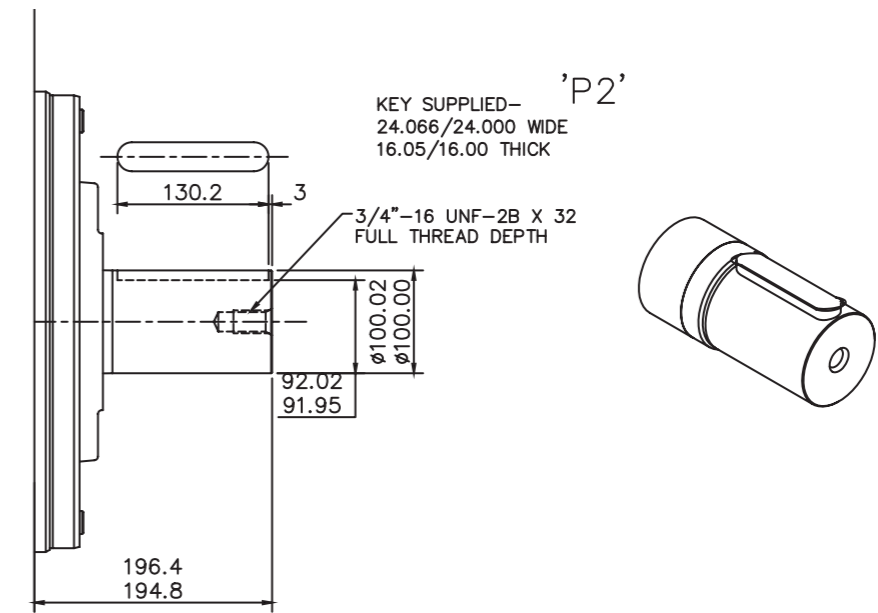

SPLINE DATA	
BS3550 : FLAT ROOT SIDE FIT	
NUMBER OF TEETH	34
PITCH	12/24
MAJOR DIAMETER	74.41/74.08
MINOR DIAMETER	69.98/69.85
PIN DIAMETER	3.66 flatted to 3.56
DIMENSION BETWEEN PINS	66.81/66.74

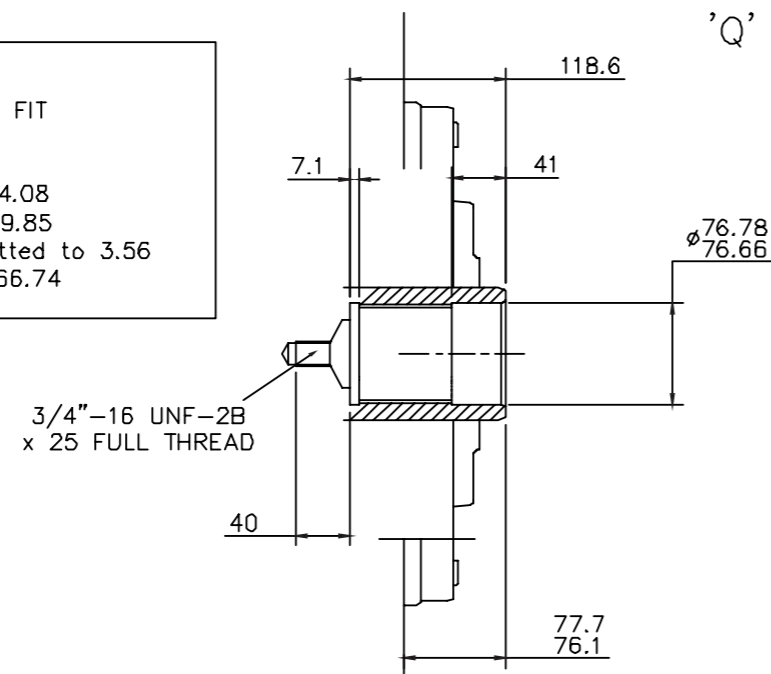

3-5 HM(HD)B125 (cont)

HMHDB125 - 'S5' & 'Z5' Shafts

SPLINE DATA

'S5'	
PRESSURE ANGLE	20°
NUMBER OF TEETH	23
PITCH	6/12
MAJOR DIAMETER	100.652/100.526
FORM DIAMETER	92.939
MINOR DIAMETER	92.184/91.626
PIN DIAMETER	8.128
DIAMETER OVER PINS	109.573/109.517

'Z5'	
DIN 5480 W100 x 4 x 24 x 7h	

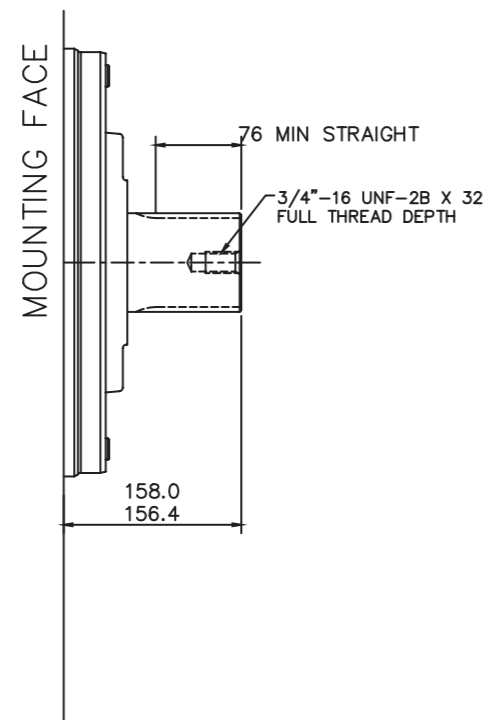

'S5' & 'Z5'

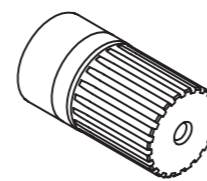

3-5 HM(HD)B125 (cont)

Installation

3/4"-16 UNF-2B DRAIN (CHOICE OF 3 POSITIONS)
(2 NORMALLY PLUGGED)
NOTE - ENSURE ON INSTALLATION THAT DRAIN IS TAKEN FROM ABOVE MOTOR CENTRELINE.
DO NOT EXCEED 12 DEPTH OF COUPLING IN TO DRAIN PORT.

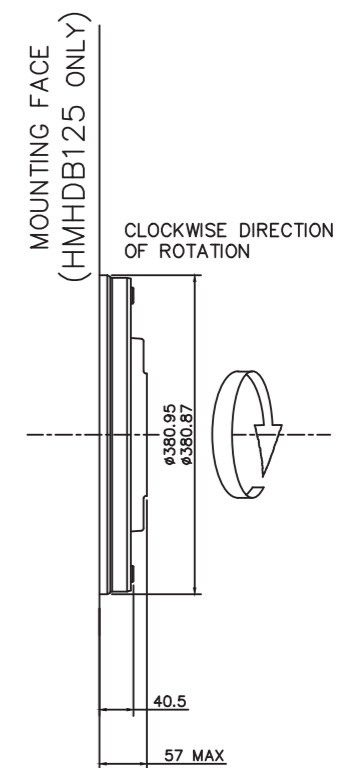
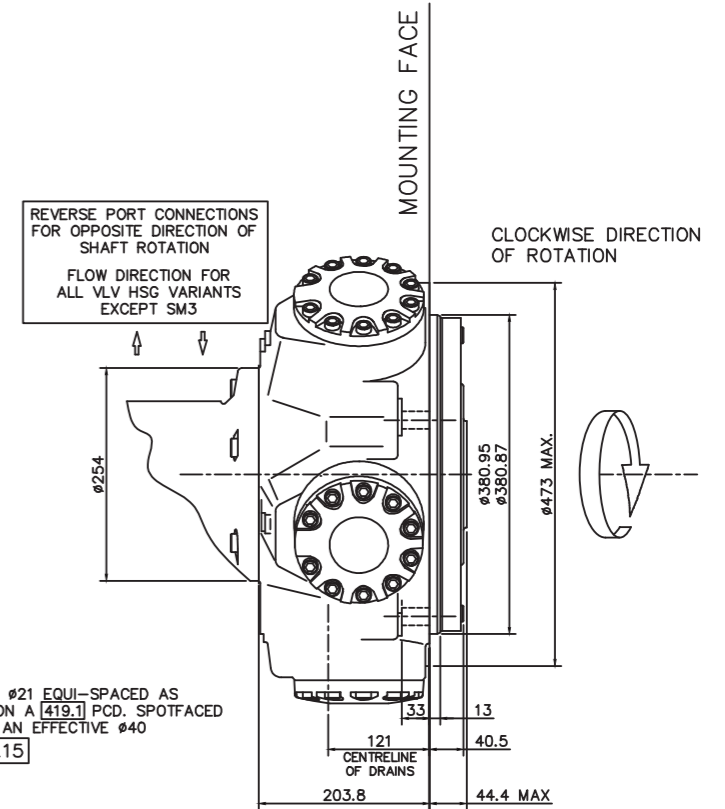
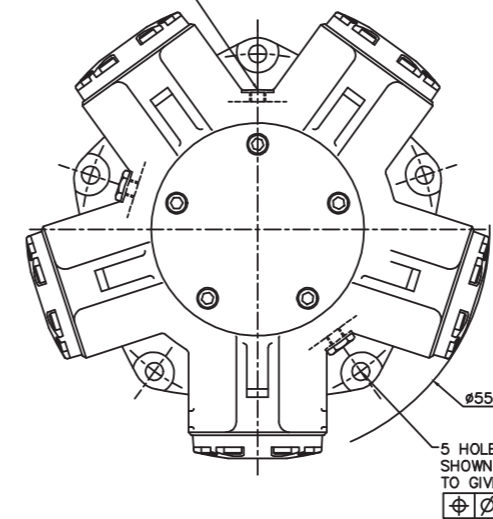

3-6 HM(HD)B150/200

HMB150/200 - 'P1', 'S3', 'S4' & 'Z3' Shafts

SPLINE DATA

'S3'	
TO BS 3550 (ANSI B92.1, CLASS 5)	
FLAT ROOT SIDE FIT, CLASS 1	
PRESSURE ANGLE	30°
NUMBER OF TEETH	20
PITCH	6/12
MAJOR DIAMETER	87.953/87.825
FORM DIAMETER	80.264
MINOR DIAMETER	79.485/78.925
PIN DIAMETER	8.128
DIAMETER OVER PINS	97.084/97.030
'S4'	
PRESSURE ANGLE	20°
NUMBER OF TEETH	16
PITCH	5/10
MAJOR DIAMETER	86.360/86.233
FORM DIAMETER	76.124
MINOR DIAMETER	74.93/72.39
PIN DIAMETER	8.636
DIAMETER OVER PINS	92.710/92.581
'Z3'	
DIN 5480 W85 x 3 x 27 x 7h	

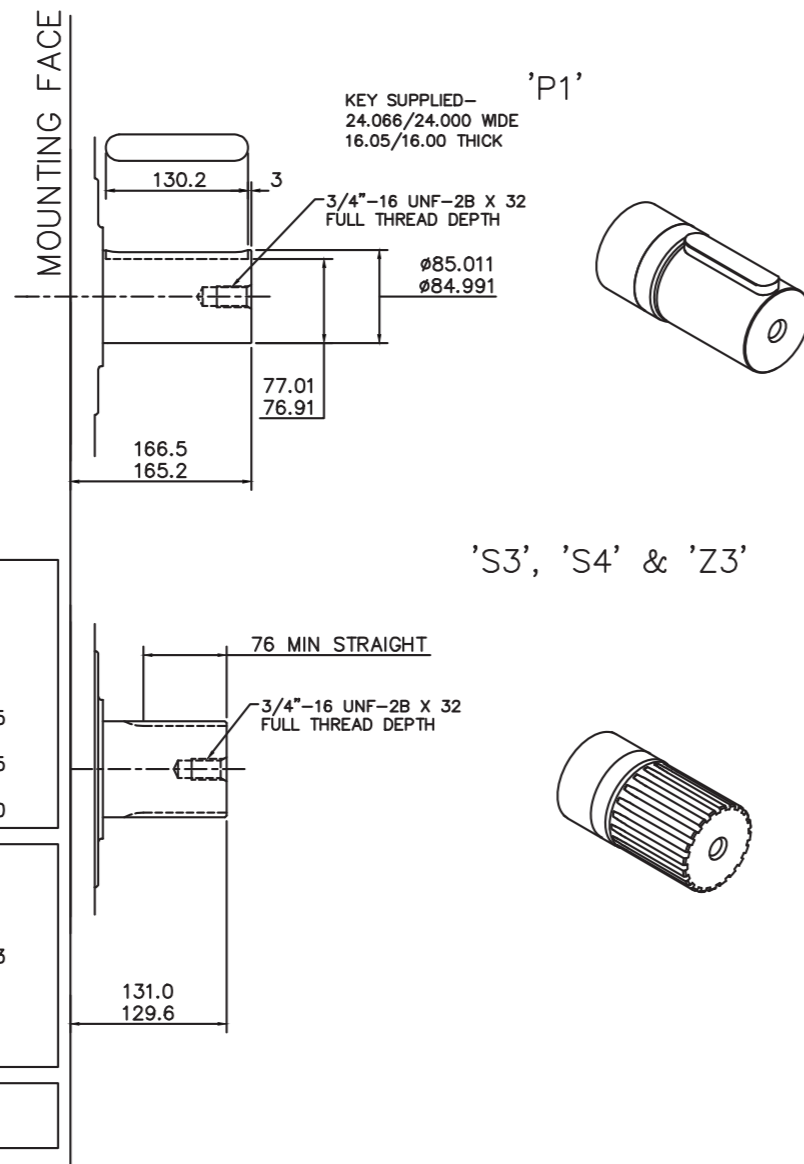

3-6 HM(HD)B150/200 (cont)

HMB150/200 - 'T' Shaft

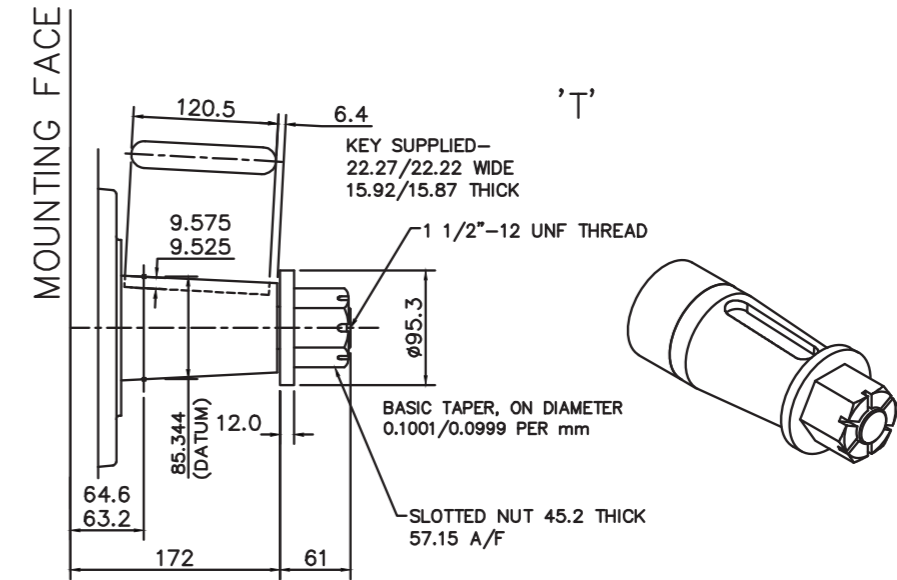

3-6 HM(HD)B150/200 (cont)

HMHDB150/200 - 'P2', 'S5' & 'Z5' Shafts

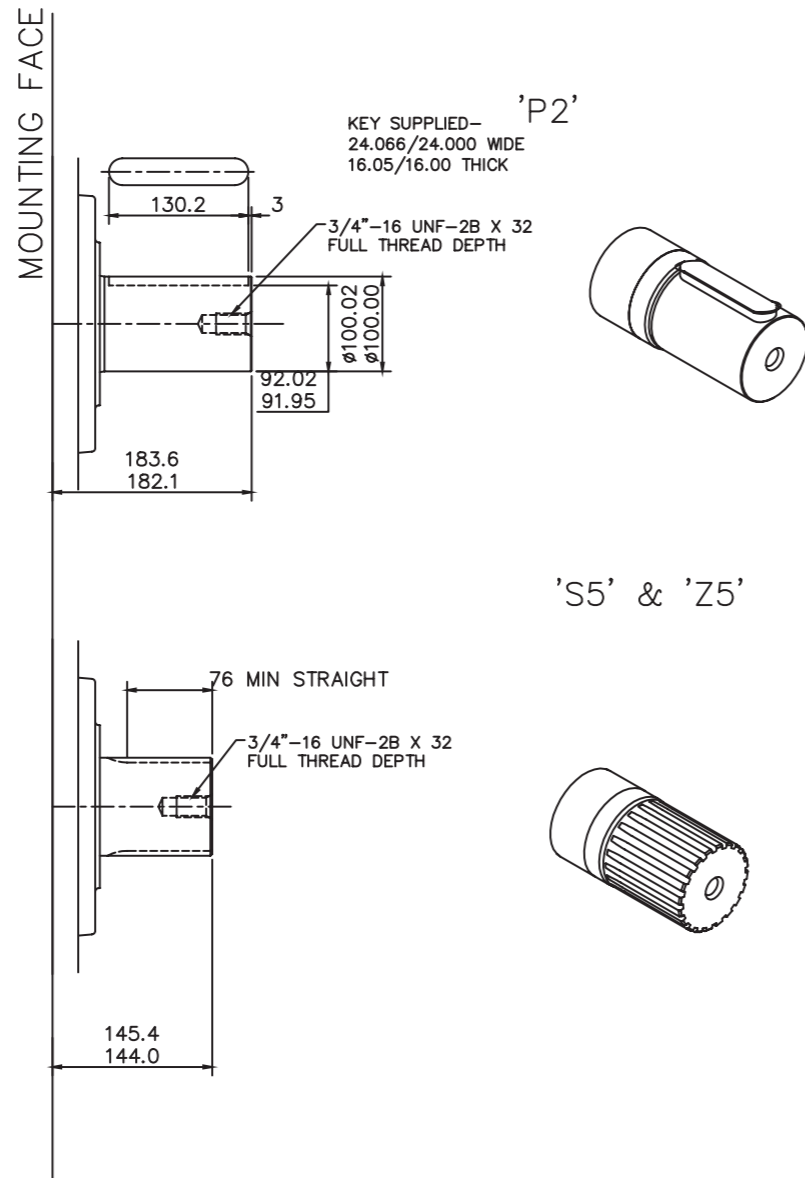

SPLINE DATA

'S5'	
PRESSURE ANGLE	30°
NUMBER OF TEETH	23
PITCH	6/12
MAJOR DIAMETER	100.652/100.526
FORM DIAMETER	92.939
MINOR DIAMETER	92.184/91.626
PIN DIAMETER	8.128
DIAMETER OVER PINS	109.573/109.517
'Z5'	
DIN 5480 W100 x 4 x 24 x 7h	

3-6 HM(HD)B150/200 (cont)

HMHDB150/200 - 'Q' Shafts

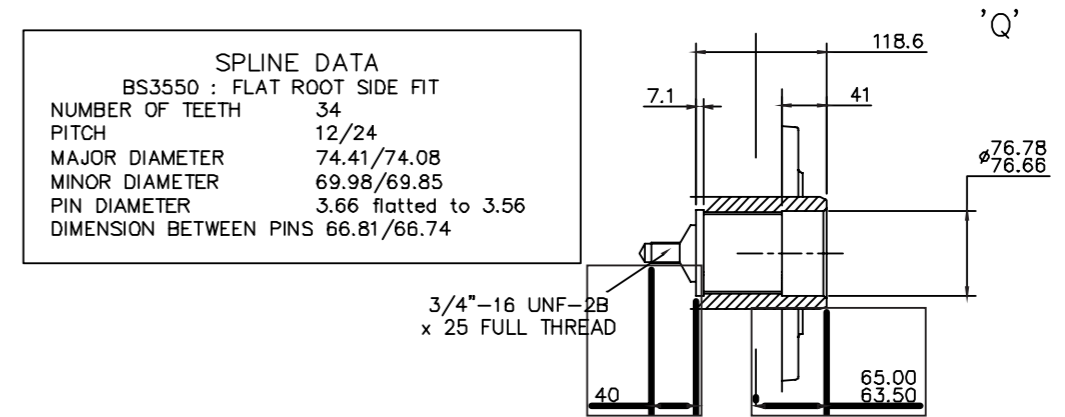

3-6 HM(HD)B150/200 (cont)

Installation

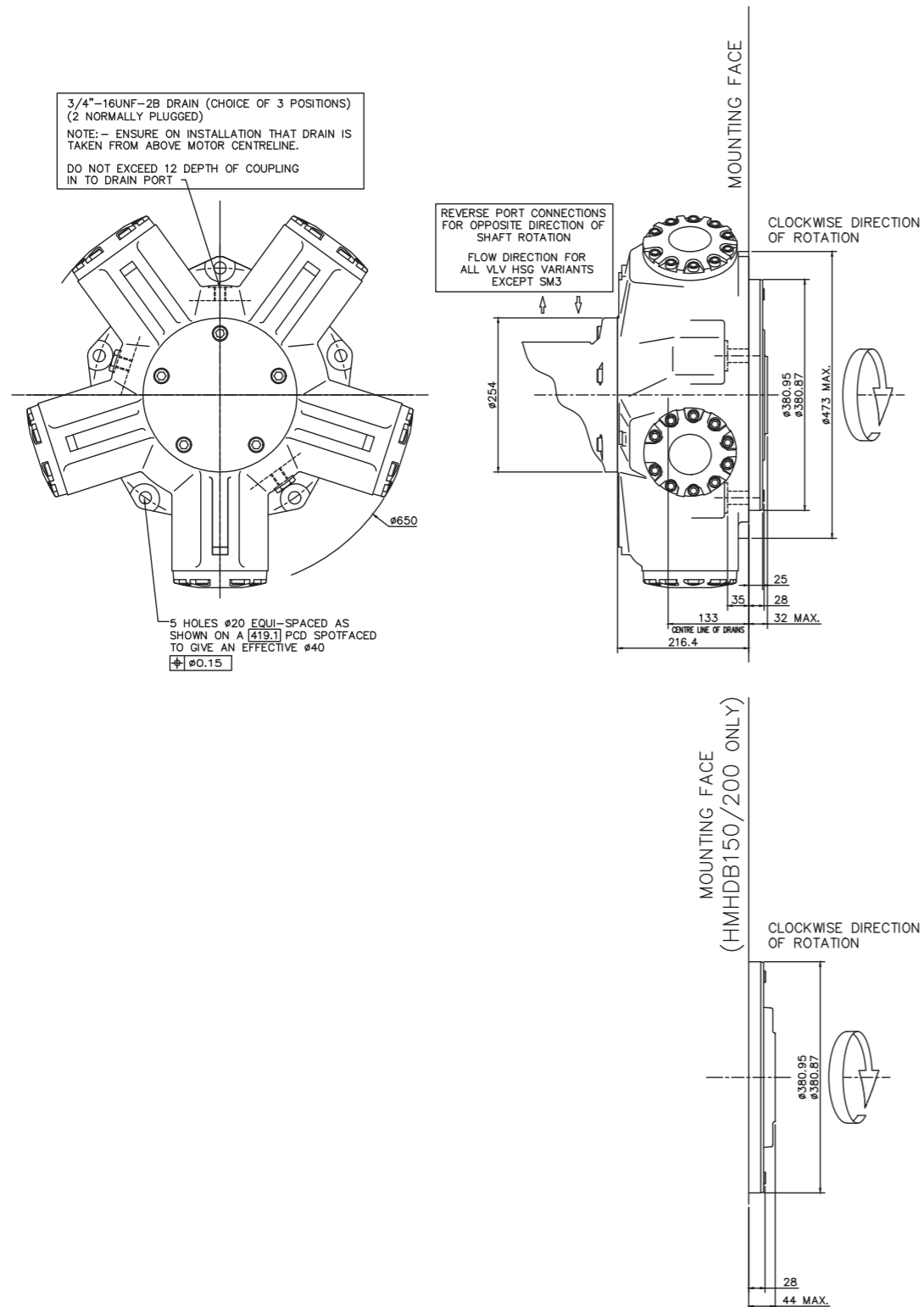

3-7 HM(HD)B270

HMB270 - 'P1', 'S3' & 'Z' Shafts

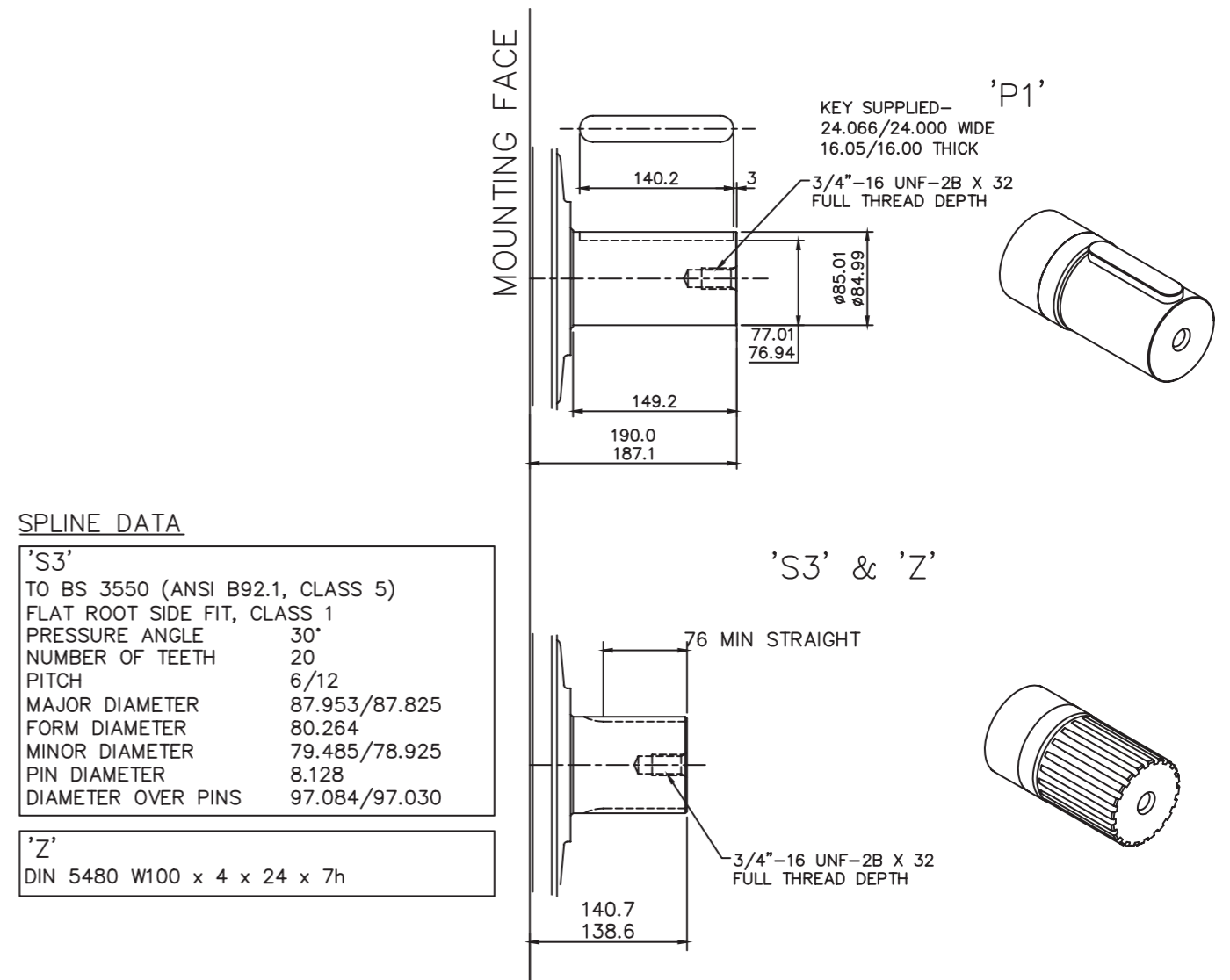

3-7 HM(HD)B270 (cont)

HMB270 - 'T' & 'Q' Shaft

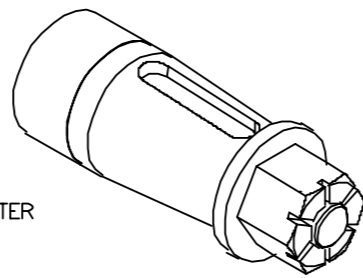
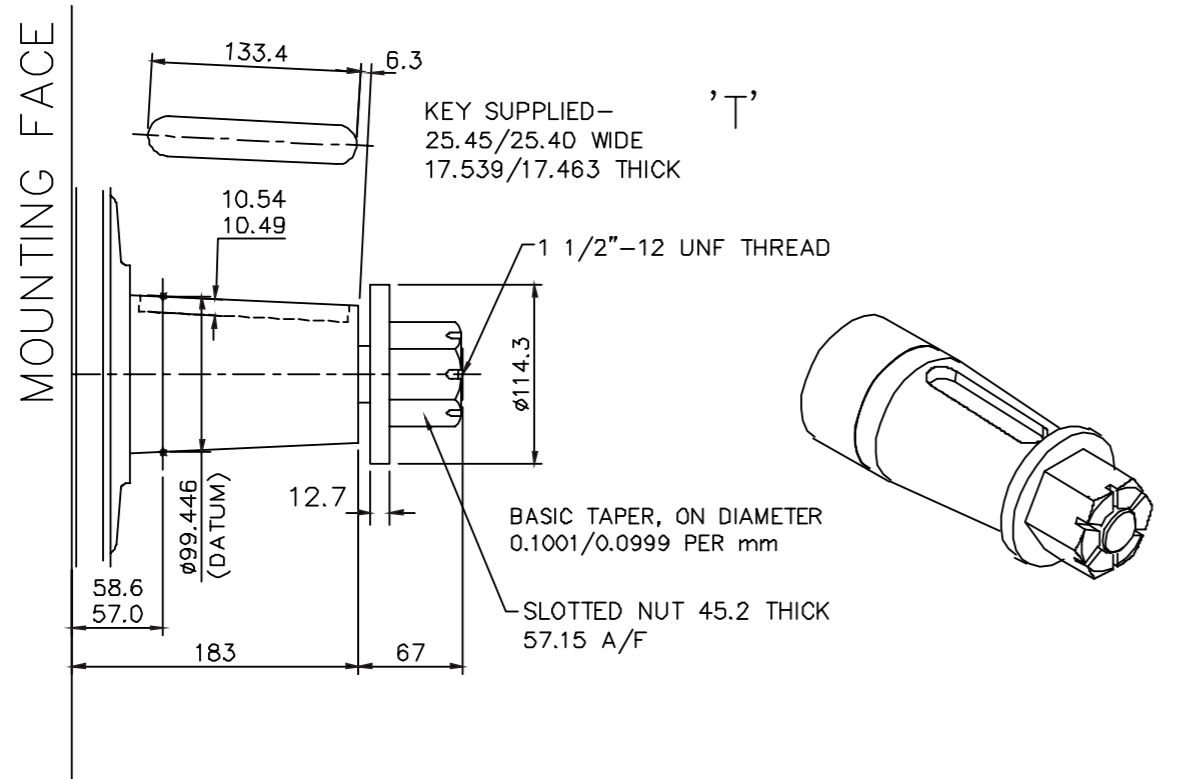

'Q'

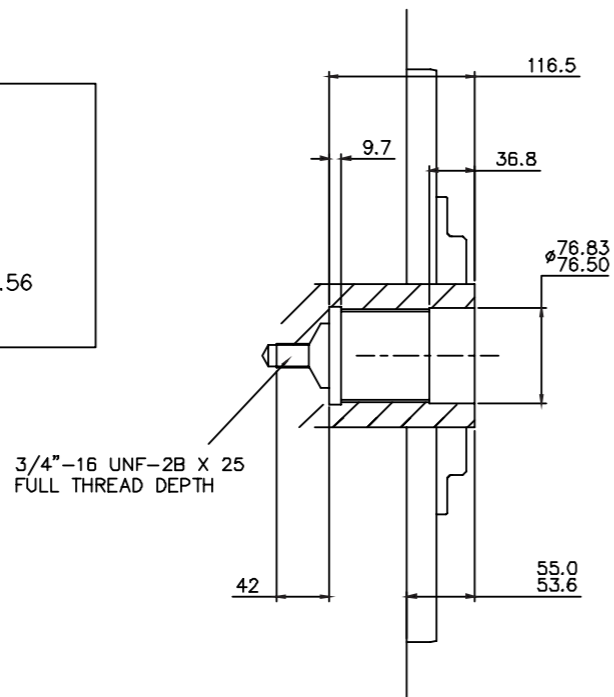

SPLINE DATA	
BS3550 : FLAT ROOT SIDE FIT	
NUMBER OF TEETH	34
PITCH	12/24
MAJOR DIAMETER	74.41/74.08
MINOR DIAMETER	69.98/69.85
PIN DIAMETER	3.66 flatted to 3.56
DIMENSION BETWEEN PINS	66.81/66.74

3-7 HM(HD)B270 (cont)

HMHDB270 - 'P2' & 'S5' Shafts

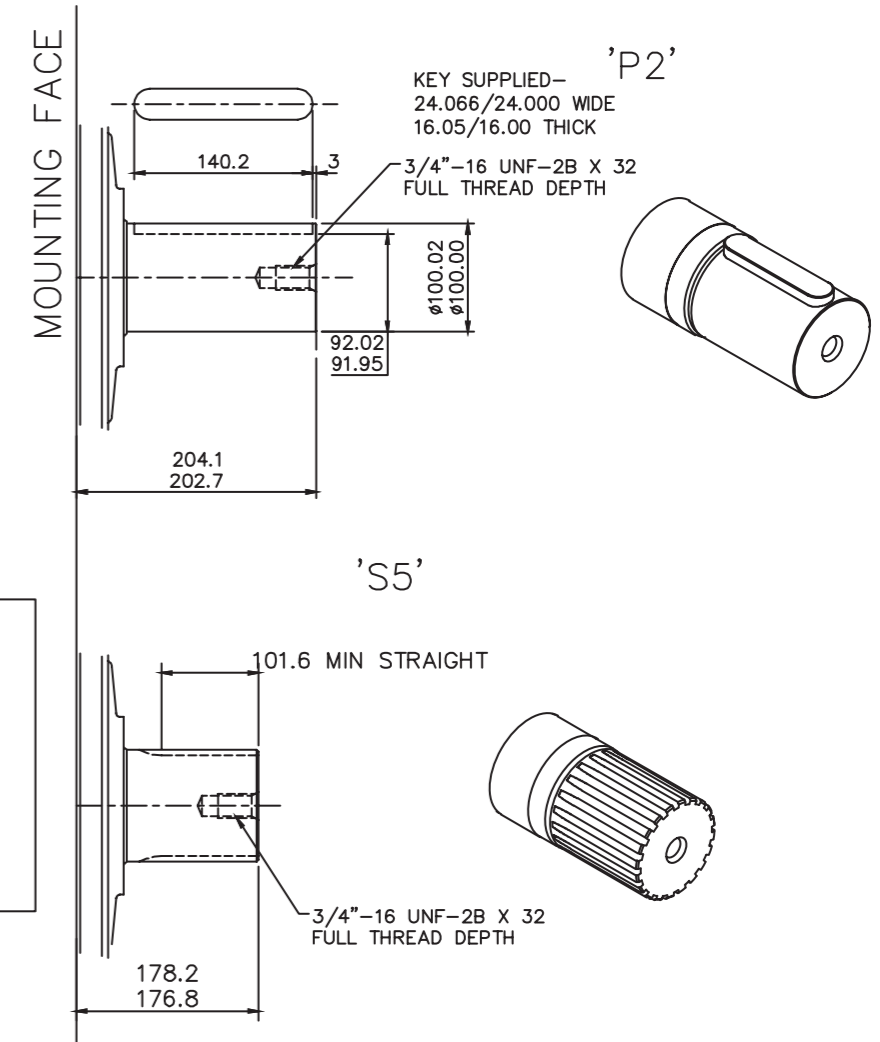

SPLINE DATA

'S3'	
TO BS 3550 (ANSI B92.1, CLASS 5)	
FLAT ROOT SIDE FIT, CLASS 1	
PRESSURE ANGLE	30°
NUMBER OF TEETH	23
PITCH	6/12
MAJOR DIAMETER	100.653/100.526
FORM DIAMETER	92.939
MINOR DIAMETER	92.184/91.625
PIN DIAMETER	8.128
DIAMETER OVER PINS	109.573/109.517

3-7 HM(HD)B270 (cont)

HMHDB270 - 'Z' Shaft

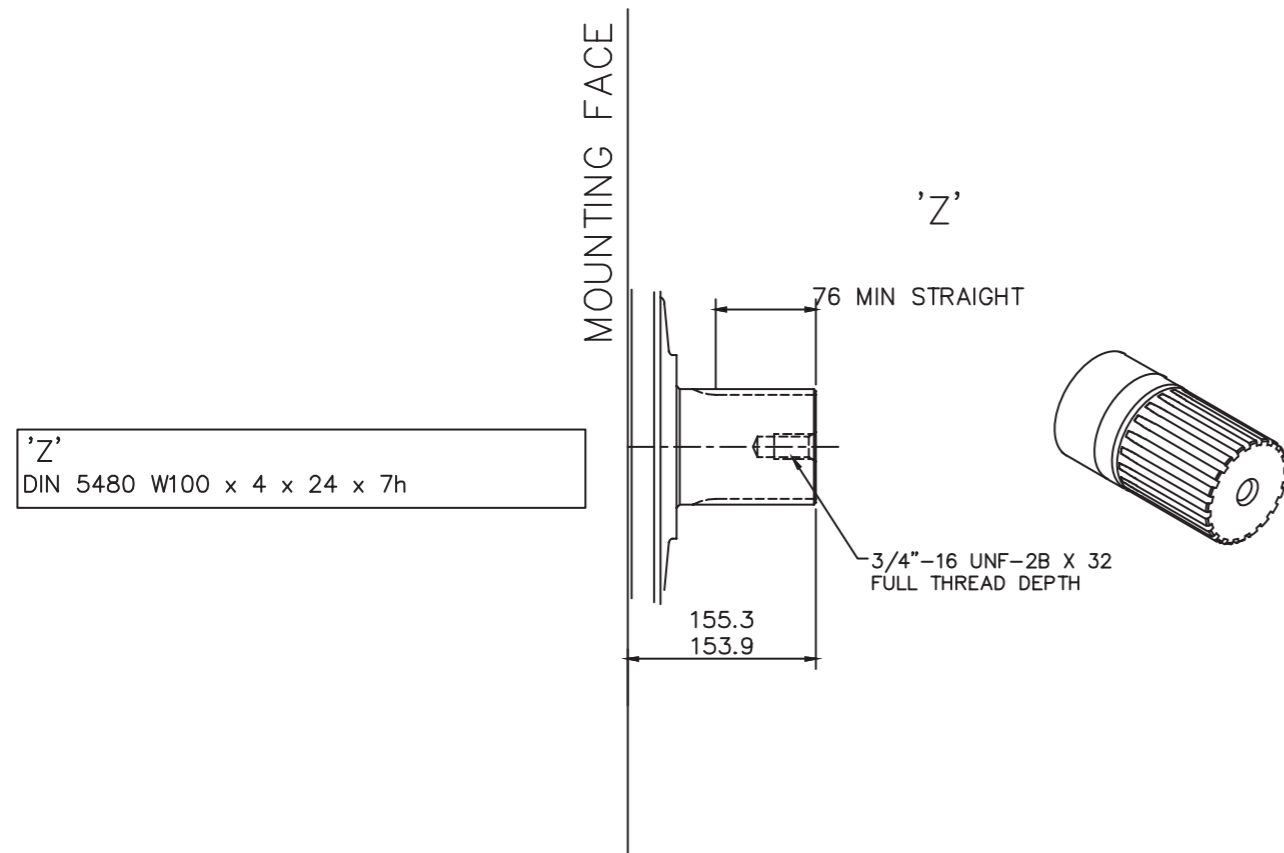

3-7 HM(HD)B270 (cont)

Installation

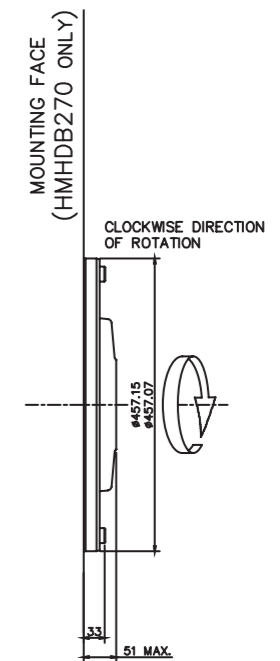
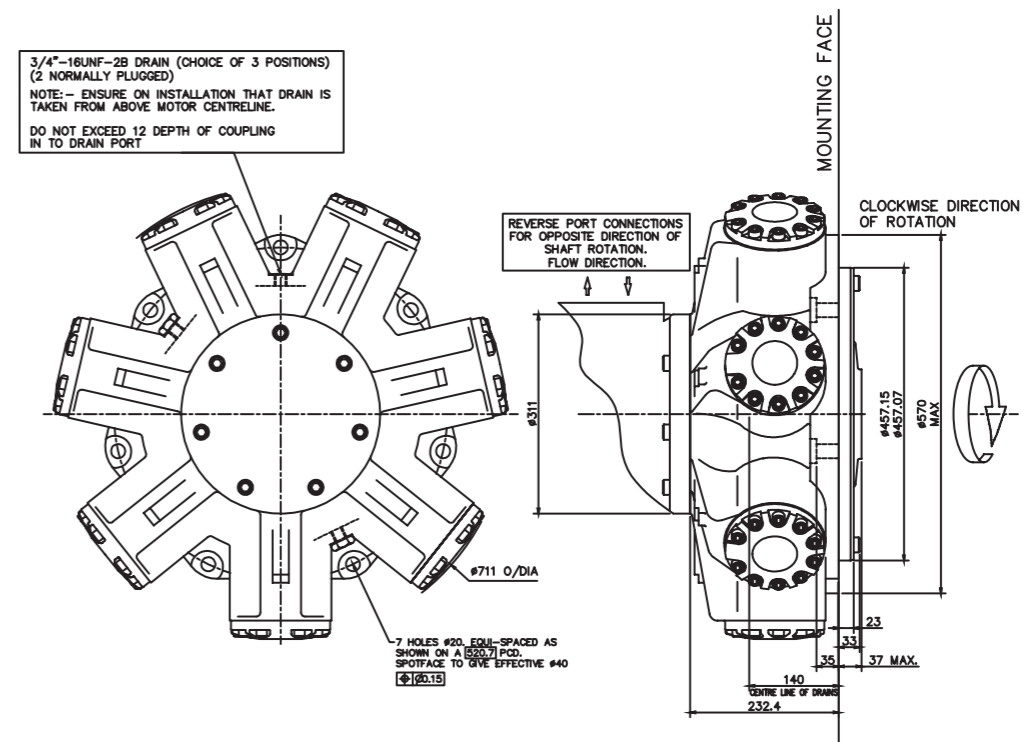

3-8 HM(HD)B325

HMB325 - 'P1', 'S3' & 'Z' Shafts

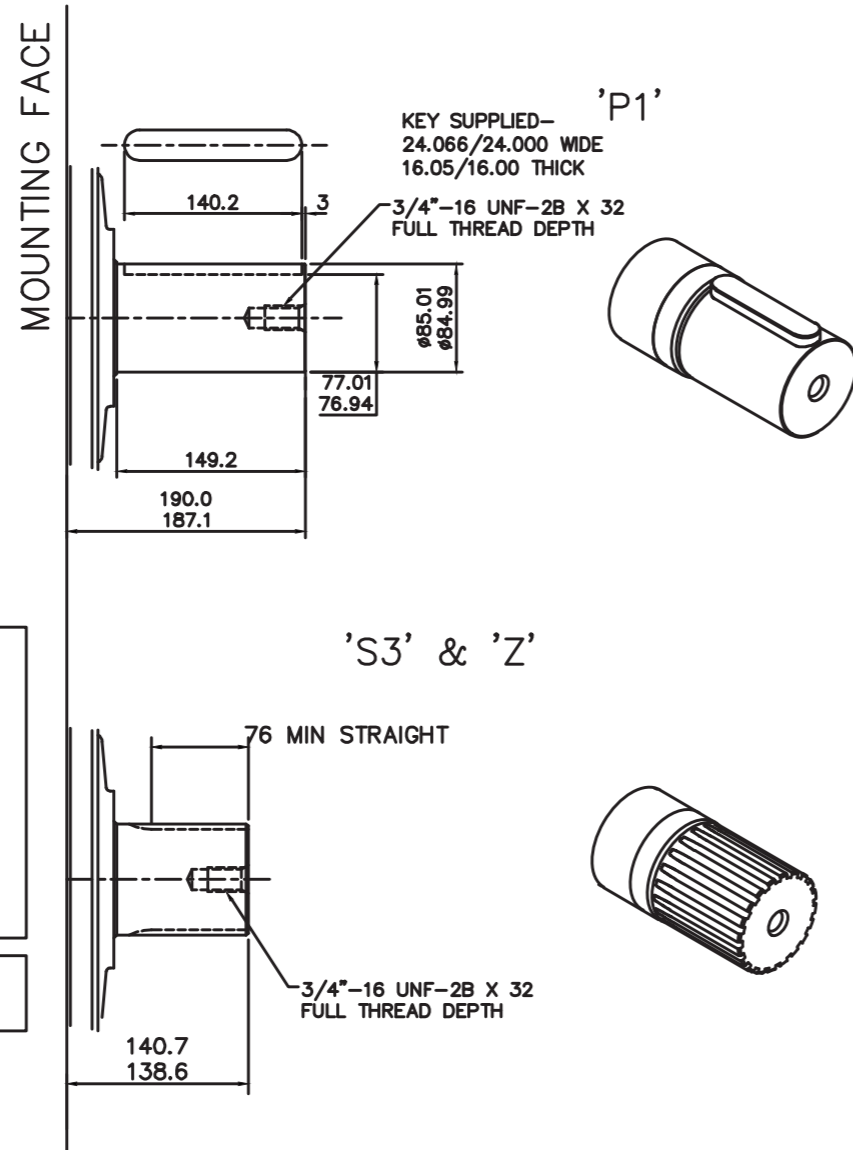

SPLINE DATA

'S3'	
TO BS 3550 (ANSI B92.1, CLASS 5)	
FLAT ROOT SIDE FIT, CLASS 1	
PRESSURE ANGLE	30°
NUMBER OF TEETH	20
PITCH	6/12
MAJOR DIAMETER	87.953/87.825
FORM DIAMETER	80.264
MINOR DIAMETER	79.485/78.925
PIN DIAMETER	8.128
DIAMETER OVER PINS	97.084/97.030

'Z'	
DIN 5480 W100 x 4 x 24 x 7h	

3-8 HM(HD)B325 (cont)

HMB325 - 'T' & 'Q' Shaft

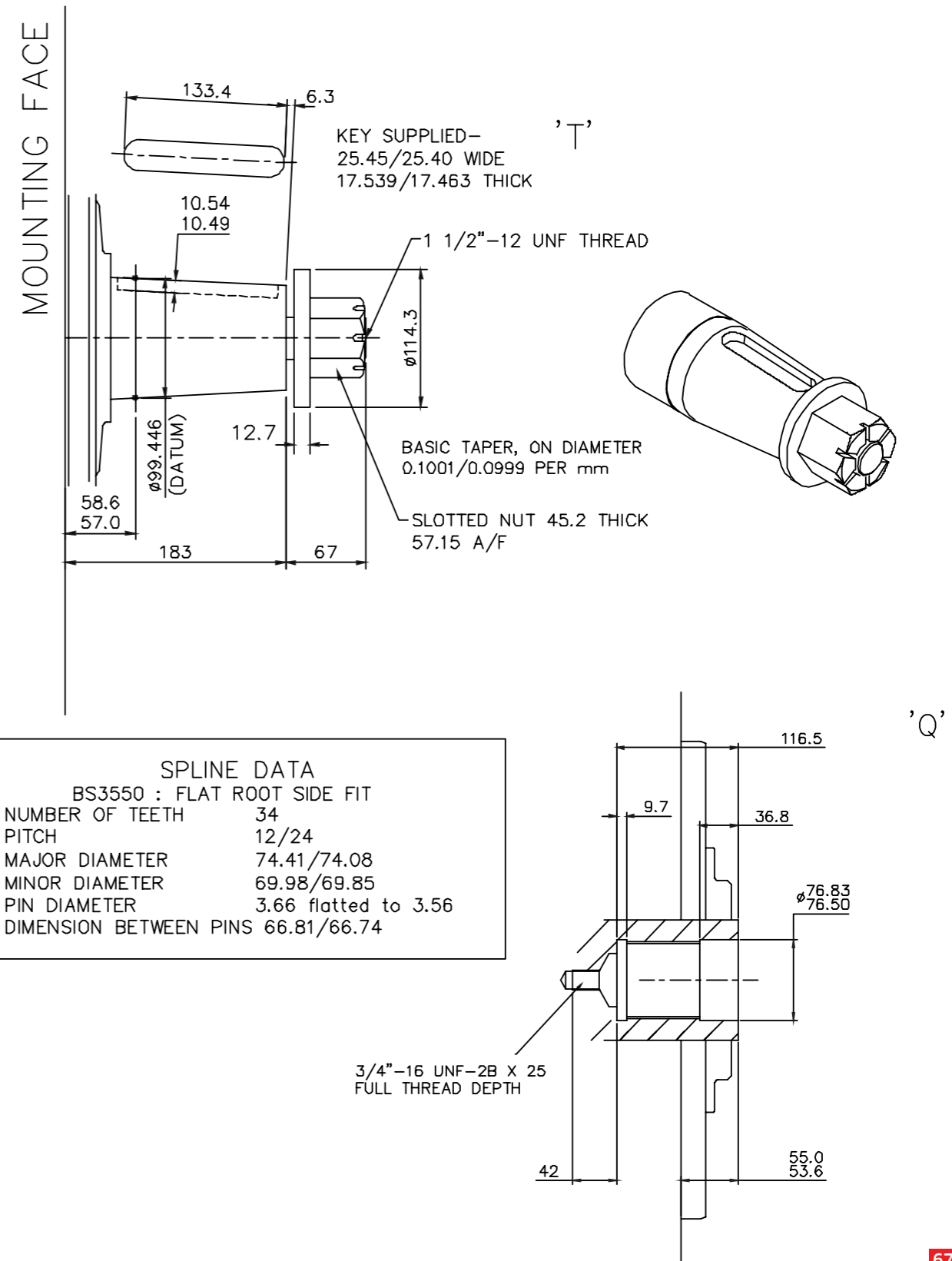

SPLINE DATA	
BS3550 : FLAT ROOT SIDE FIT	
NUMBER OF TEETH	34
PITCH	12/24
MAJOR DIAMETER	74.41/74.08
MINOR DIAMETER	69.98/69.85
PIN DIAMETER	3.66 flatted to 3.56
DIMENSION BETWEEN PINS	66.81/66.74

3-8 HM(HD)B325 (cont)

HMHDB325 - 'P2' & 'S5' Shafts

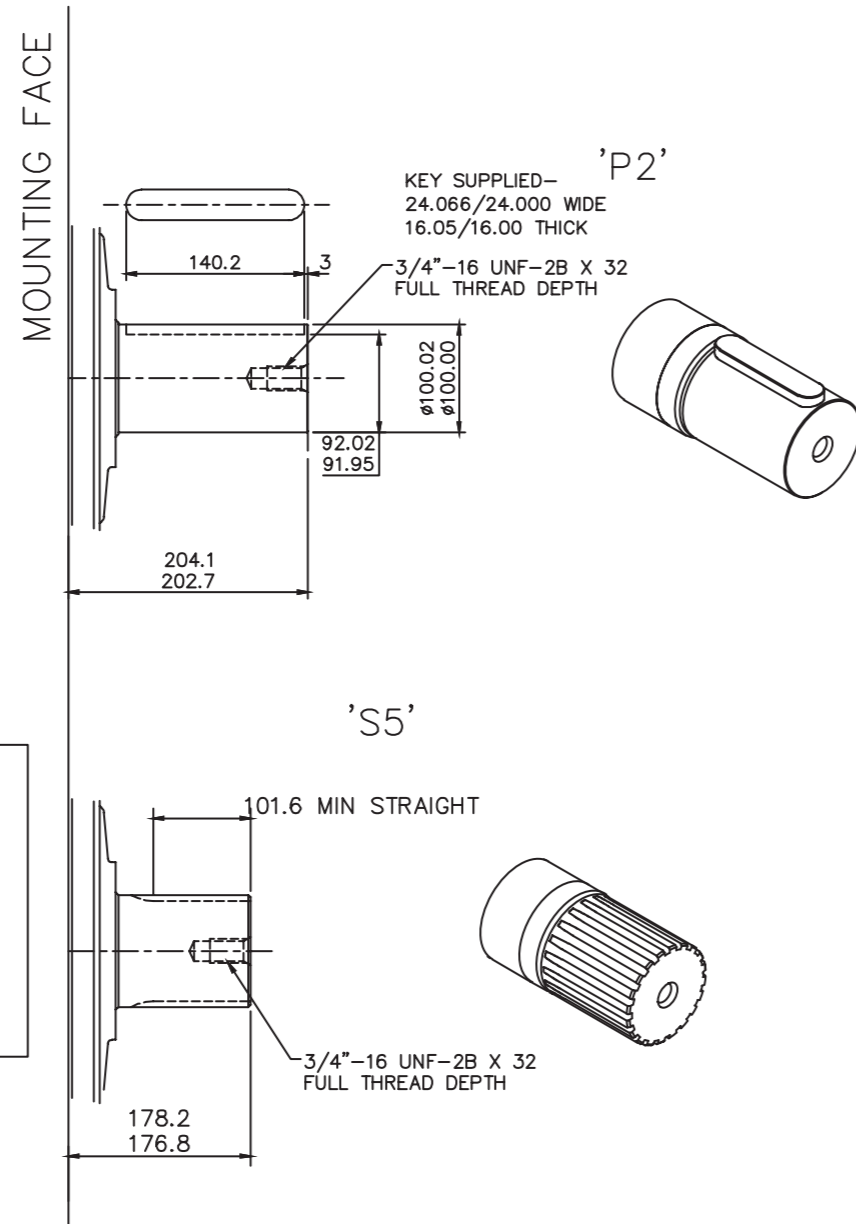

SPLINE DATA

'S3'	
TO BS 3550 (ANSI B92.1, CLASS 5)	
FLAT ROOT SIDE FIT, CLASS 1	
PRESSURE ANGLE	30°
NUMBER OF TEETH	23
PITCH	6/12
MAJOR DIAMETER	100.653/100.526
FORM DIAMETER	92.939
MINOR DIAMETER	92.184/91.625
PIN DIAMETER	8.128
DIAMETER OVER PINS	109.573/109.517

3-8 HM(HD)B325 (cont)

HMHDB325 - 'Z' Shaft

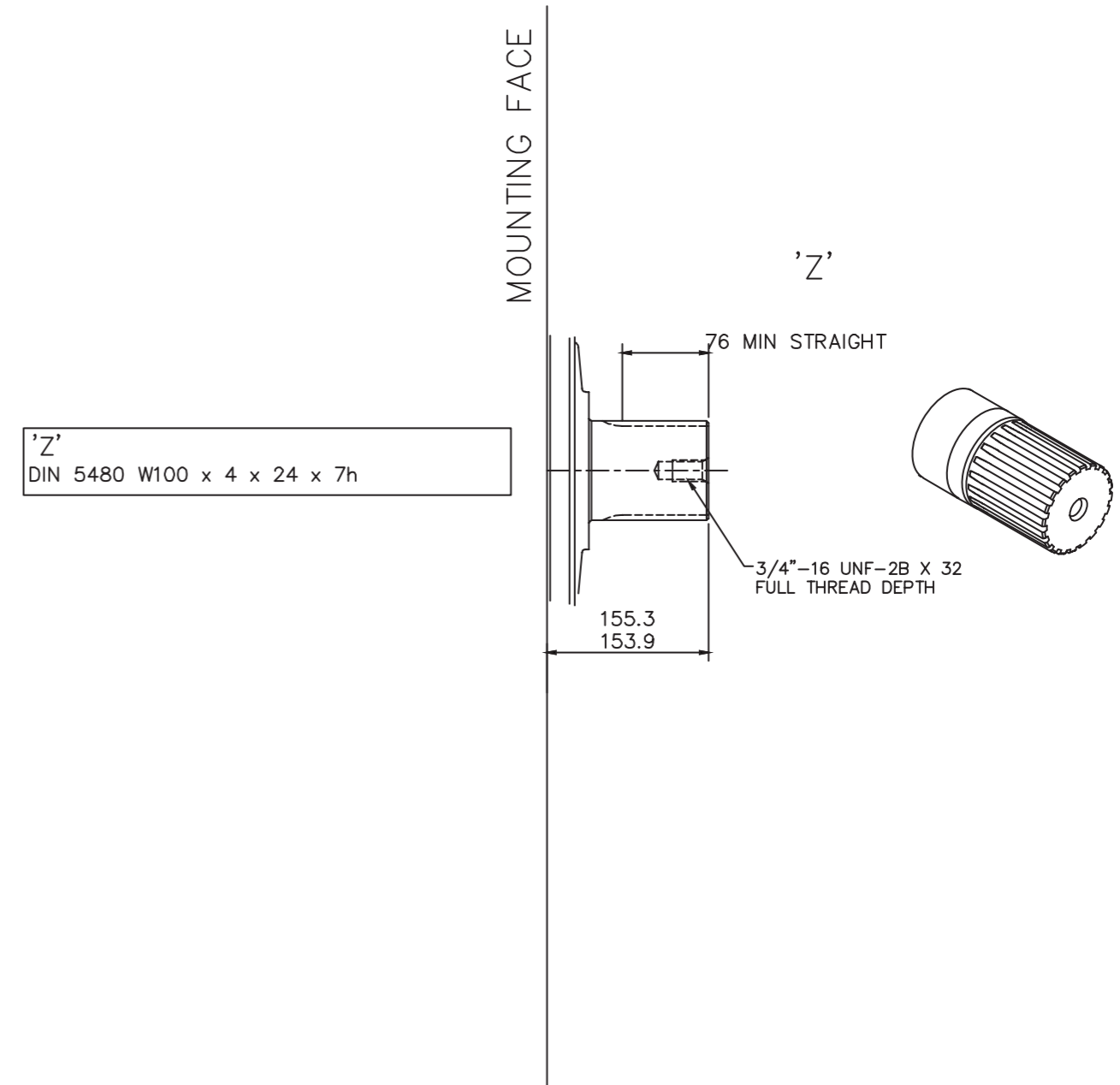

3-8 HM(HD)B325 (cont)

Installation

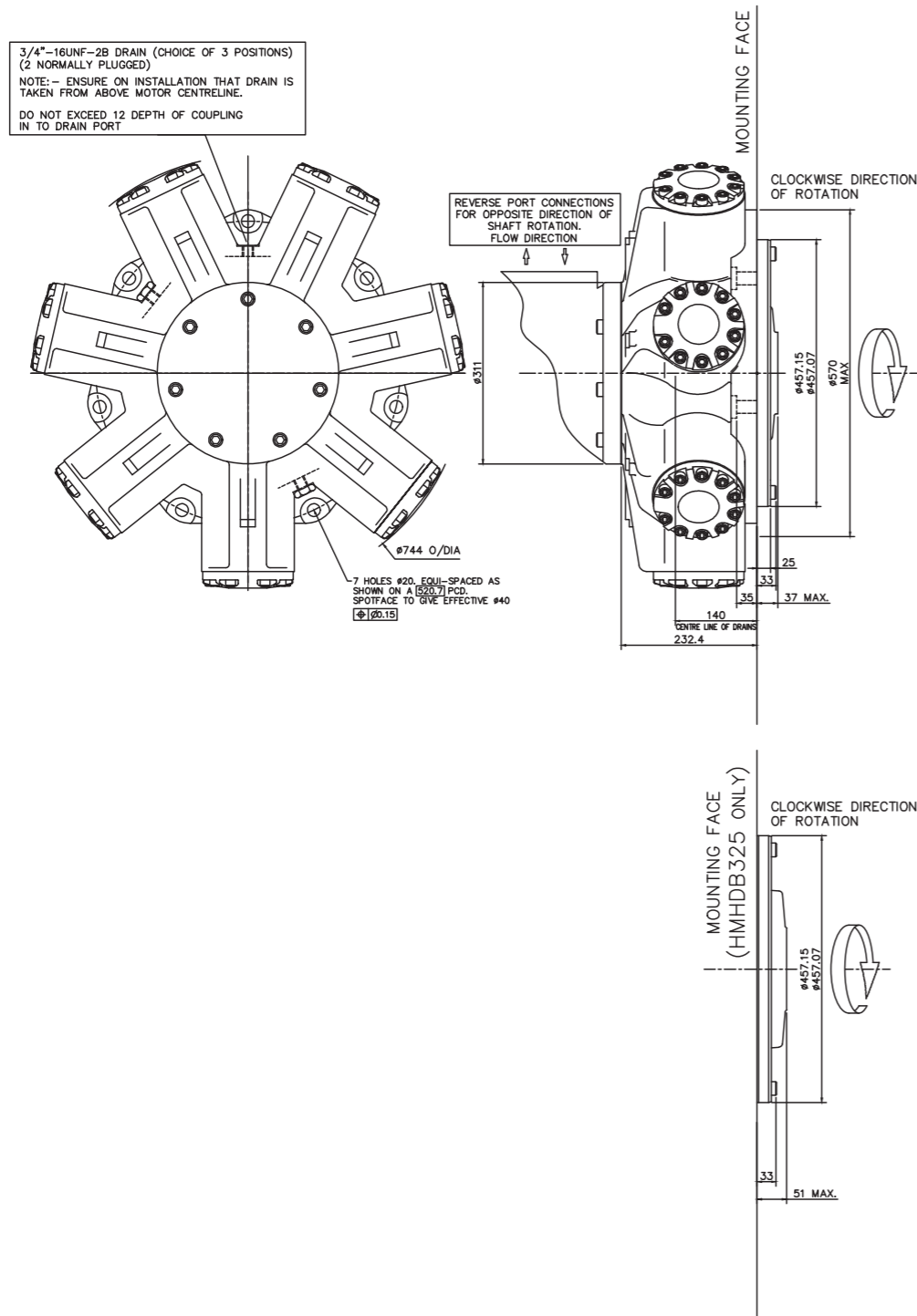

3-9 HMHDB400

'P', 'S' & 'Z' Shafts

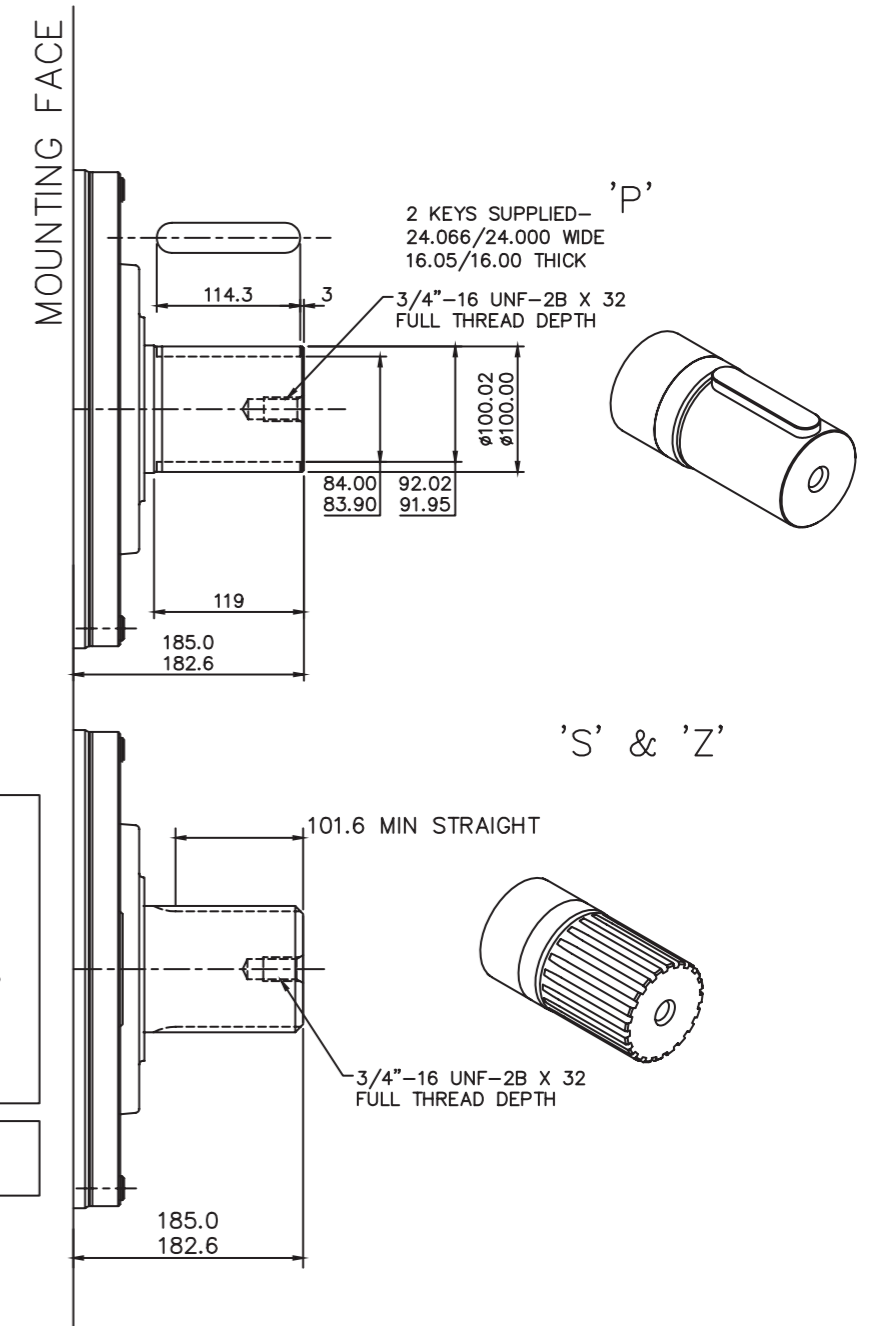

SPLINE DATA

'S'	
TO BS 3550 (ANSI B92.1, CLASS 5)	
FLAT ROOT SIDE FIT, CLASS 1	
PRESSURE ANGLE	30°
NUMBER OF TEETH	23
PITCH	6/12
MAJOR DIAMETER	100.653/100.526
FORM DIAMETER	92.939
MINOR DIAMETER	92.184/91.625
PIN DIAMETER	8.128
DIAMETER OVER PINS	109.573/109.517

'Z'	
DIN 5480 W100 x 4 x 24 x 7h	

3-9 HMB400 (cont)

Installation

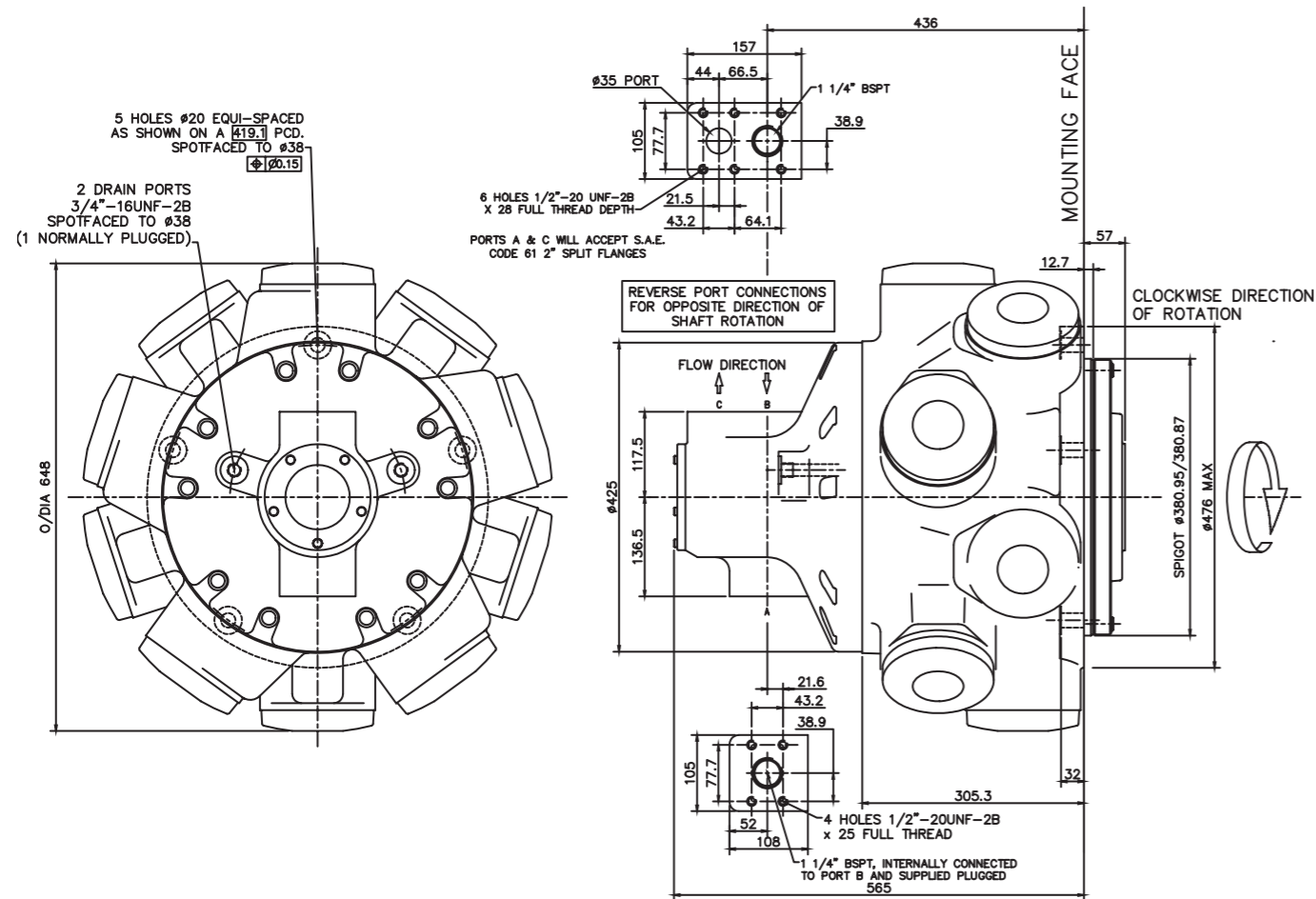

3-10 HMB500

'P', 'S' & 'Z' Shafts

SPLINE DATA

'S'	TO BS 3550 (ANSI B92.1, CLASS 5)
	FLAT ROOT SIDE FIT, CLASS 1
	PRESSURE ANGLE 30°
	NUMBER OF TEETH 23
	PITCH 6/12
	MAJOR DIAMETER 100.653/100.526
	FORM DIAMETER 92.939
	MINOR DIAMETER 92.184/91.625
	PIN DIAMETER 8.128
	DIAMETER OVER PINS 109.573/109.517

'Z'	DIN 5480 W100 x 4 x 24 x 7h
-----	-----------------------------

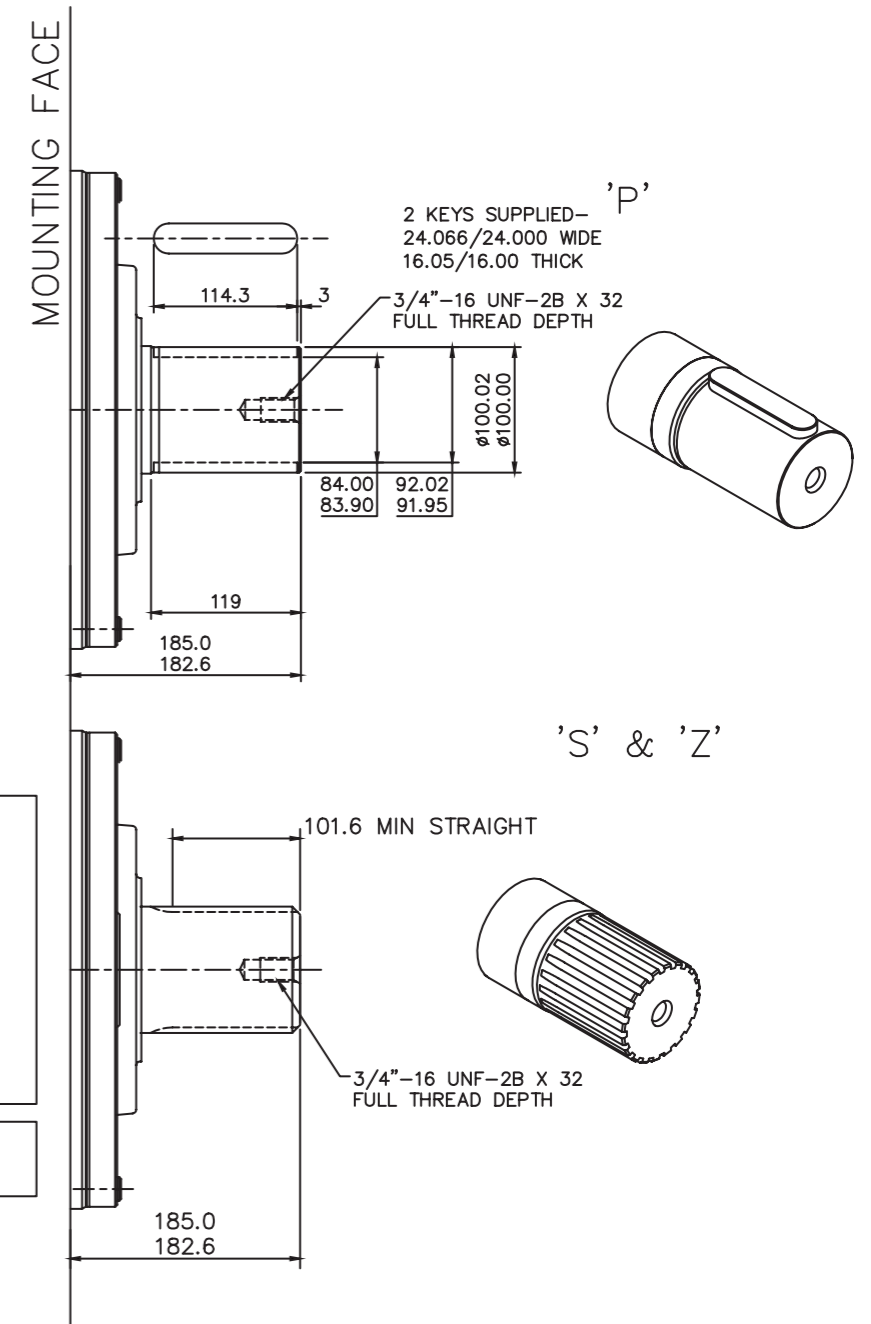

3-10 HMB500 (cont)

Installation

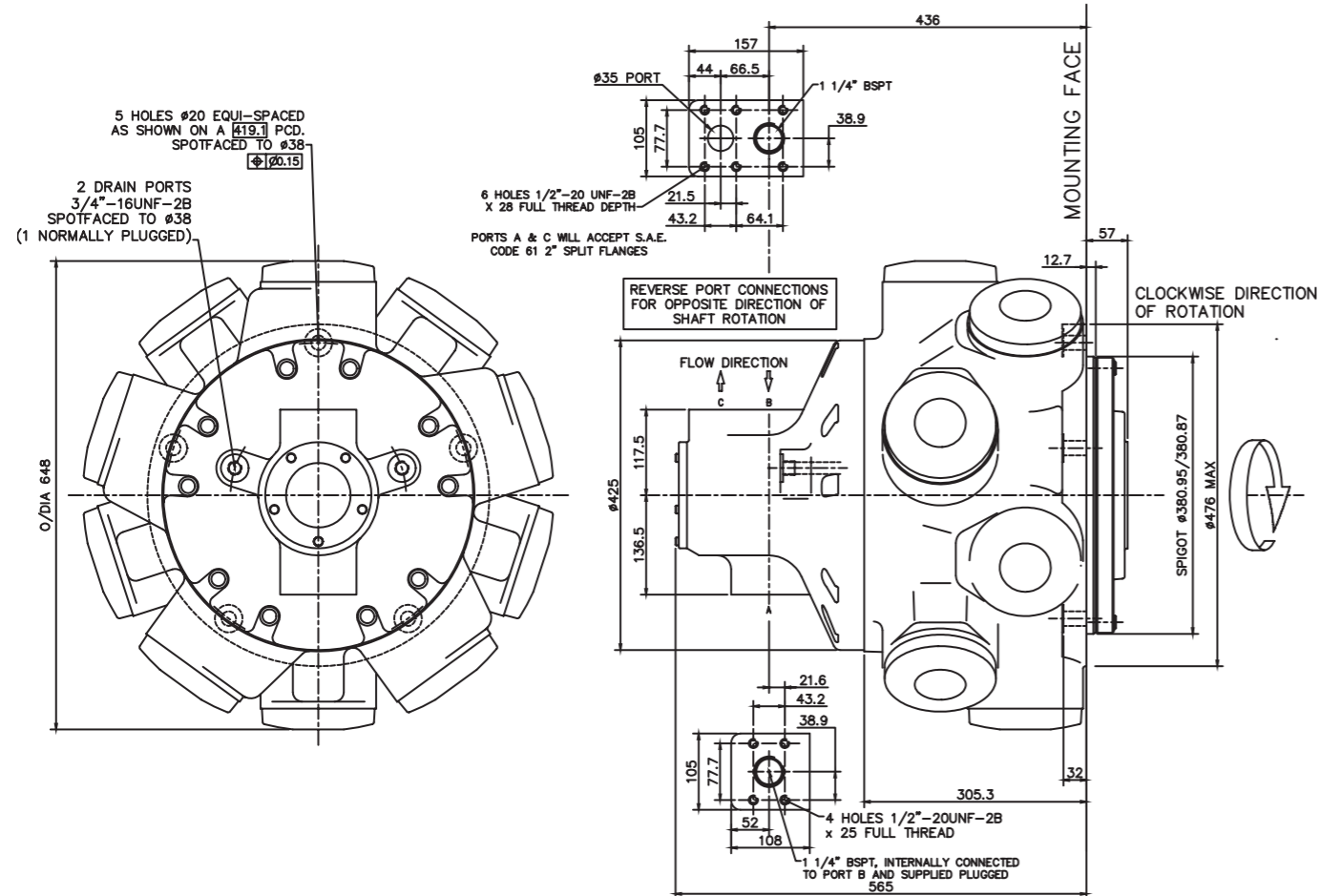

3-11 Preferred Hydraulic Connections

SAE Connections

MODEL	'SF3/SFM3' 1 1/4" Code 61 SAE Ports								
	ØS	V	T	R	W	X(SF3)	X(SFM3)	P	Q
HMB030								271	331
HMB045								300	360
HMB060/080/100	32	76	30.2	58.7	87.1	7/16"-14 UNC-2B x 27 FULL THREAD DEPTH	M12 x 1.75 x 27 FULL THREAD DEPTH	286	346
HMB125									
HMB150/200								328	388

SFM3/SF3

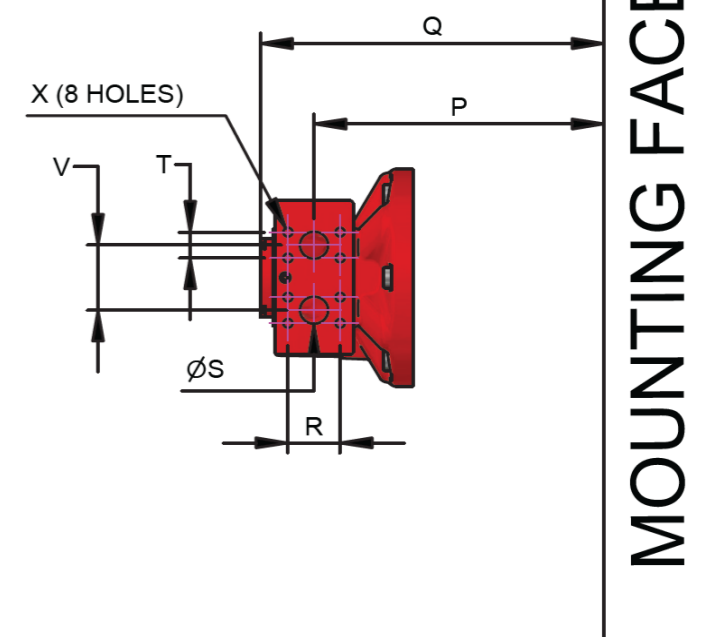
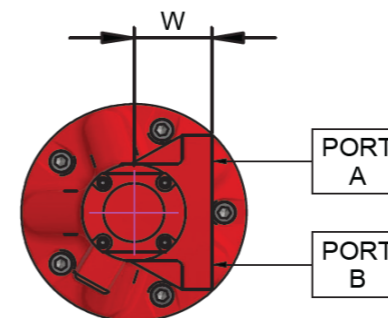

MODEL	'F3/FM3' 1 1/4" SAE Bolt Flanges									
	ØS	V	T	R	W	X(F3)	X(FM3)	P	P1	Q
HMB030	31.75	74	58.7	30.2	87	7/16"-14 UNC-2B x 27 FULL THREAD DEPTH	M12 x P1.75 x 27 FULL THREAD DEPTH	238	46.5	331
HMB045								267.5		360
HMB060/080/100								253		345
HMB125								283		375
HMB150/200								295		388

MODEL	'SF4/SFM4' 1 1/2" Code 62 SAE Ports										
	ØS	V	T	R	W	X(SF4)	X(SFM4)	P	Q		
HMB045	38.1	116	36.5	79.4	154	5/8"-11 UNC-2B x 35 FULL THREAD DEPTH	M16 x 2.0 x 35 FULL THREAD DEPTH	330	413		
HMB060/080/100								316	399		
HMB125											
HMB150/200										358	441

F3 / FM3

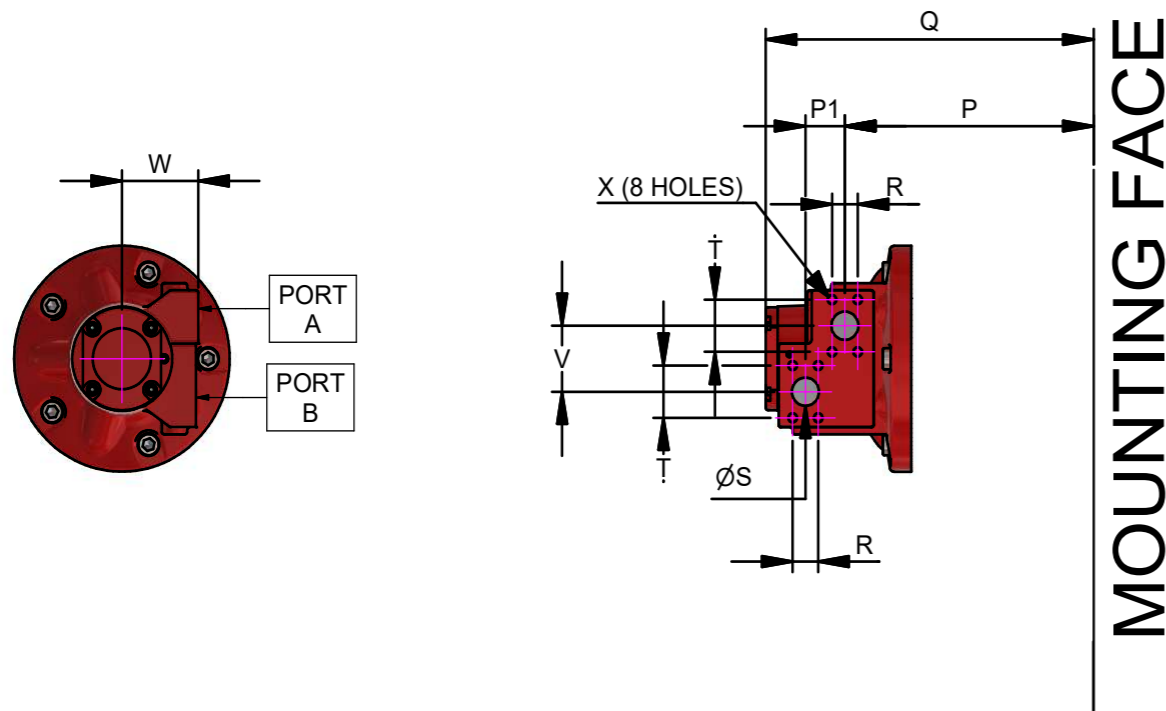

SFM4 / SF4

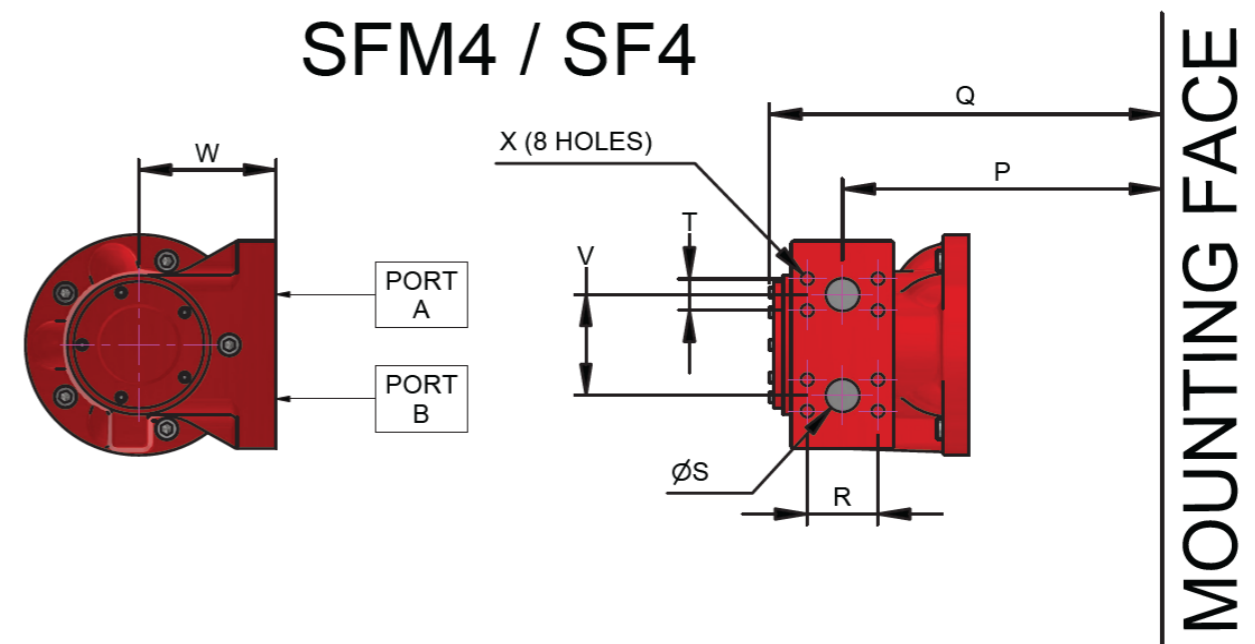

3-11 Preferred Hydraulic Connections (cont)

◆ SAE Connections - HMHDB400/500

MODEL	'FM4' 1 1/2" SAE Bolt Flanges									
	ØS	V	T	R	W	X(F4)	X(FM4)	P	P1	Q
HMB100	38.1	148	79.4	36.5	130	5/8"-11 UNC-2B x 35 FULL THREAD DEPTH	M16 x P2 x 35 FULL THREAD DEPTH	266	321	399
HMB125								296	351	429
HMB150/200								308	363	442
HMB270/325								324	379	460

MODEL	'SFM45' 2" Code 62 SAE Ports							
	ØS	v	T	R	W	F	P	Q
HM(HD)B400/500	50	120	44.5	96.8	145	M20 x 2.5 x 38 FULL THREAD DEPTH	478	567

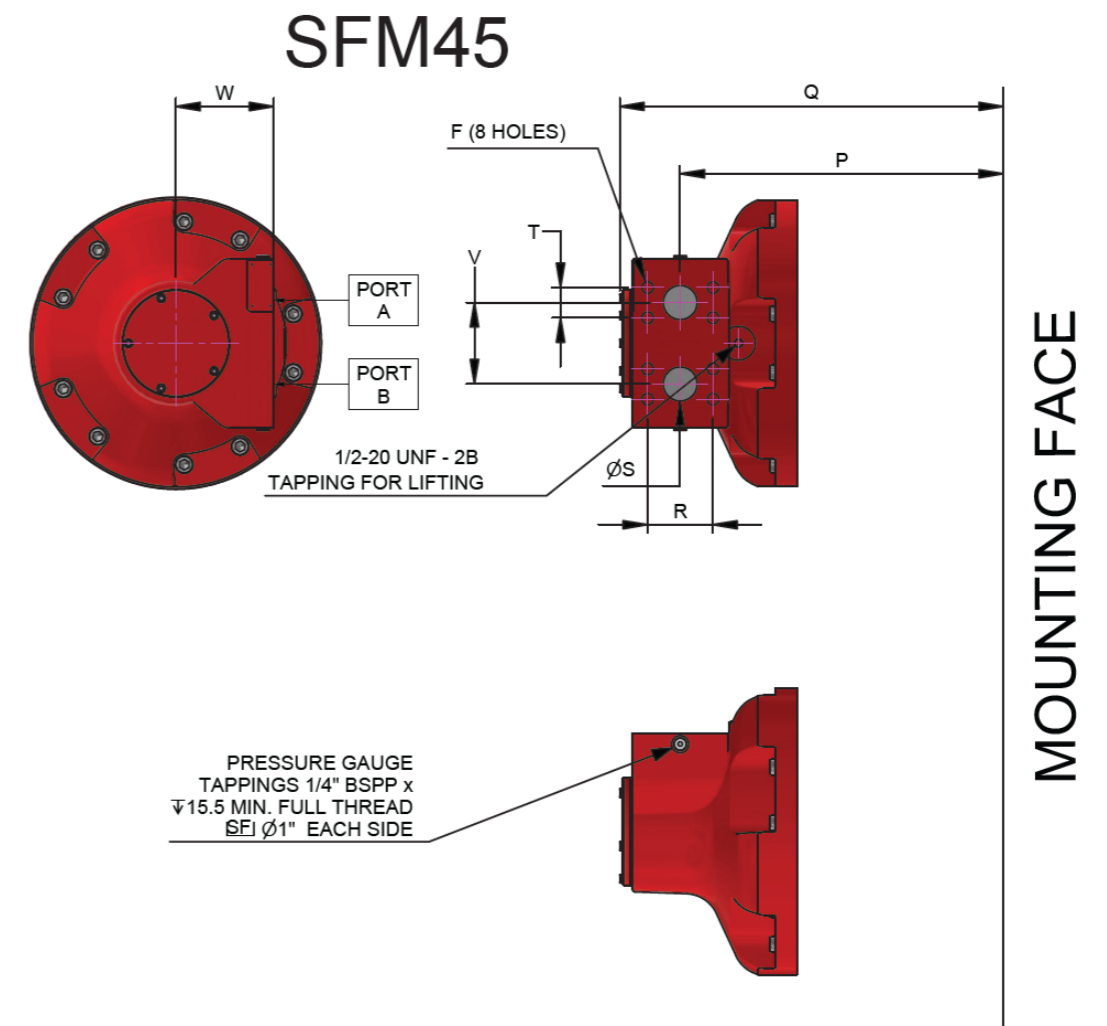
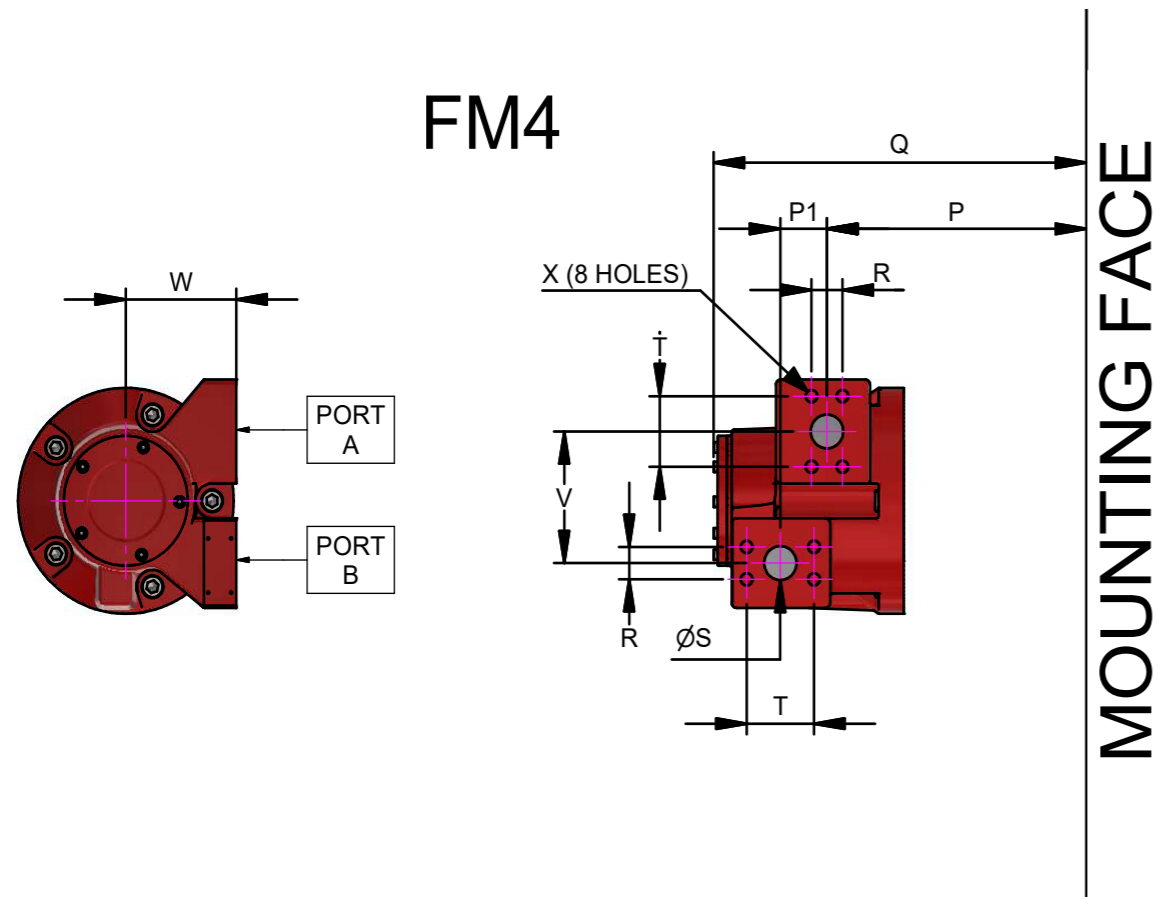

3-11 Preferred Hydraulic Connections (cont)

Manifold connections

MODEL	'SM3' 1 1/4" Ports for Bolt-On Manifold									
	ØS	V	T	R	W	P	Q	X1	X2	X3
HMB030	32	76	143	62	87.1	270.5	332	14	20	30
HMB045						300	360			
HMB060/080/100						286	346			
HMB125						315	375			
HMB150/200						358	440			
HMB270/325						385	459			

MODEL	'SM4' 1 1/2" Ports for Bolt-On Manifold										
	ØS	V	T	R	W	P	Q	X1	X2	X3	
HMB030	38.0	116	194	68	154	301	383	17	28	25	
HMB045						331	413				
HMB060/080/100						316	399				
HMB125						345	428				
HMB150/200						358	441				
HMB270/325						185	377				459

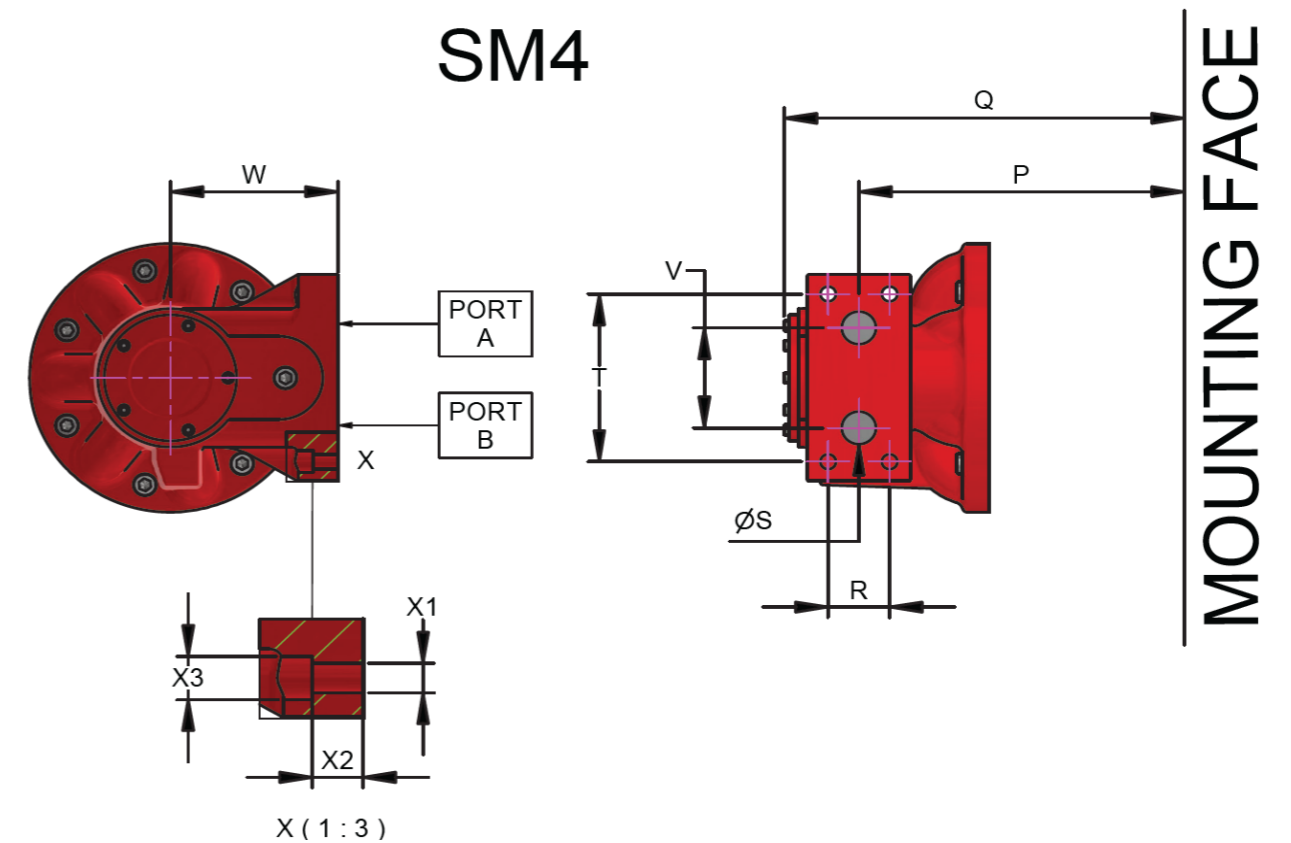
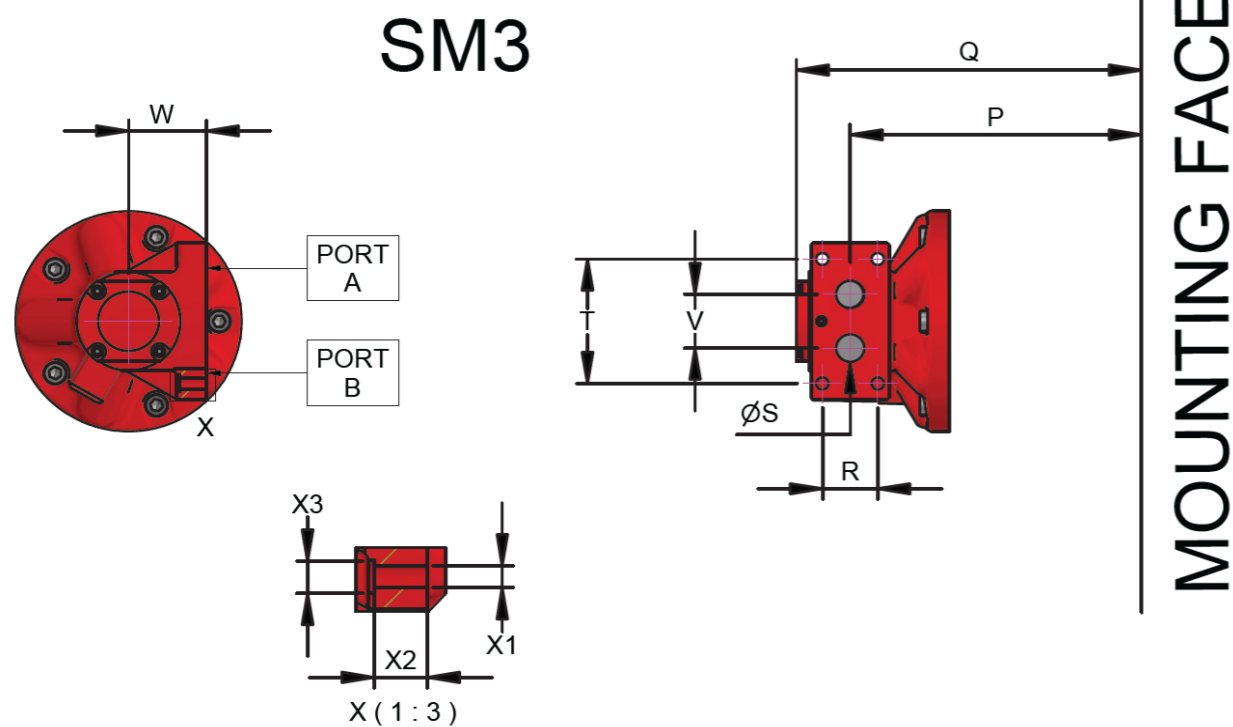

*other porting options available upon request

Conversion Table

Pressure	
bar	PSI
1	14.5
Flow	
l/min	gal/min
1	0.264 US
1	0.219 UK
Length	
mm	inch
25.4	1
Torque	
Nm	lbf ft
1	1.737
Power	
kW	hp
1	1.341
Mass	
kg	lb
1	2.2

KAWASAKI PRECISION MACHINERY (UK) LTD

Ernesettle, Plymouth
Devon, PL5 2SA, England

Tel: +44 1752 364394
Fax: +44 1752 364816
Mail: info@kpm-uk.co.uk
Website: www.kpm-eu.com

OTHER GLOBAL SALES OFFICES

JAPAN

Kawasaki Heavy Industry Ltd, Precision Machinery Ltd. Tokyo Office World Trade Center Bldg.
4-1 Hamamatsu-cho
2-chome, Minato-ku
Tokyo 105-6116
Japan
Tel: +81-3-3435-6862
Website: www.khi.co.jp/kpm

U.S.A

Kawasaki Precision Machinery (U.S.A.), Inc.
3838 Broadmoor Avenue S.E.
Grand Rapids
Michigan 49512
U.S.A.
Tel: +1-616-975-3101
Website: www.kpm-usa.com

CHINA

Kawasaki Precision Machinery Trading (Shanghai) Co., Ltd. 17th Floor (Room 1701), The Headquarters Building No168 XiZang Road (M)
Huangpu District
Shanghai 200001
China
Tel: +86-021-3366-3800

KOREA

Flutek, Ltd.
192-11, Shinchon-dong
Changwon
Kyungnam 641-370
Korea
Tel: +82-55-286-5551
Website: www.flutek.co.kr

The specified data is for product description purposes only and may not be deemed to be guaranteed unless expressly confirmed in the contract.

Data sheet:M200112.24-HMB